

# Agridoor Classic Plus Manual

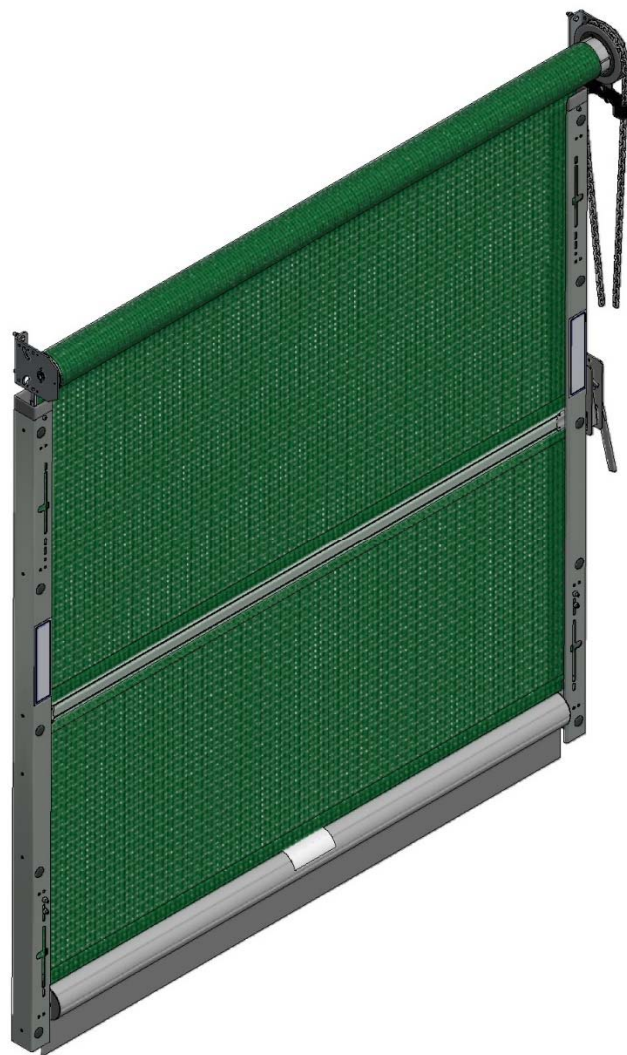

GB

## Installation and Operating Instructions

***Galebreaker***<sup>®</sup>  
— AGRI —

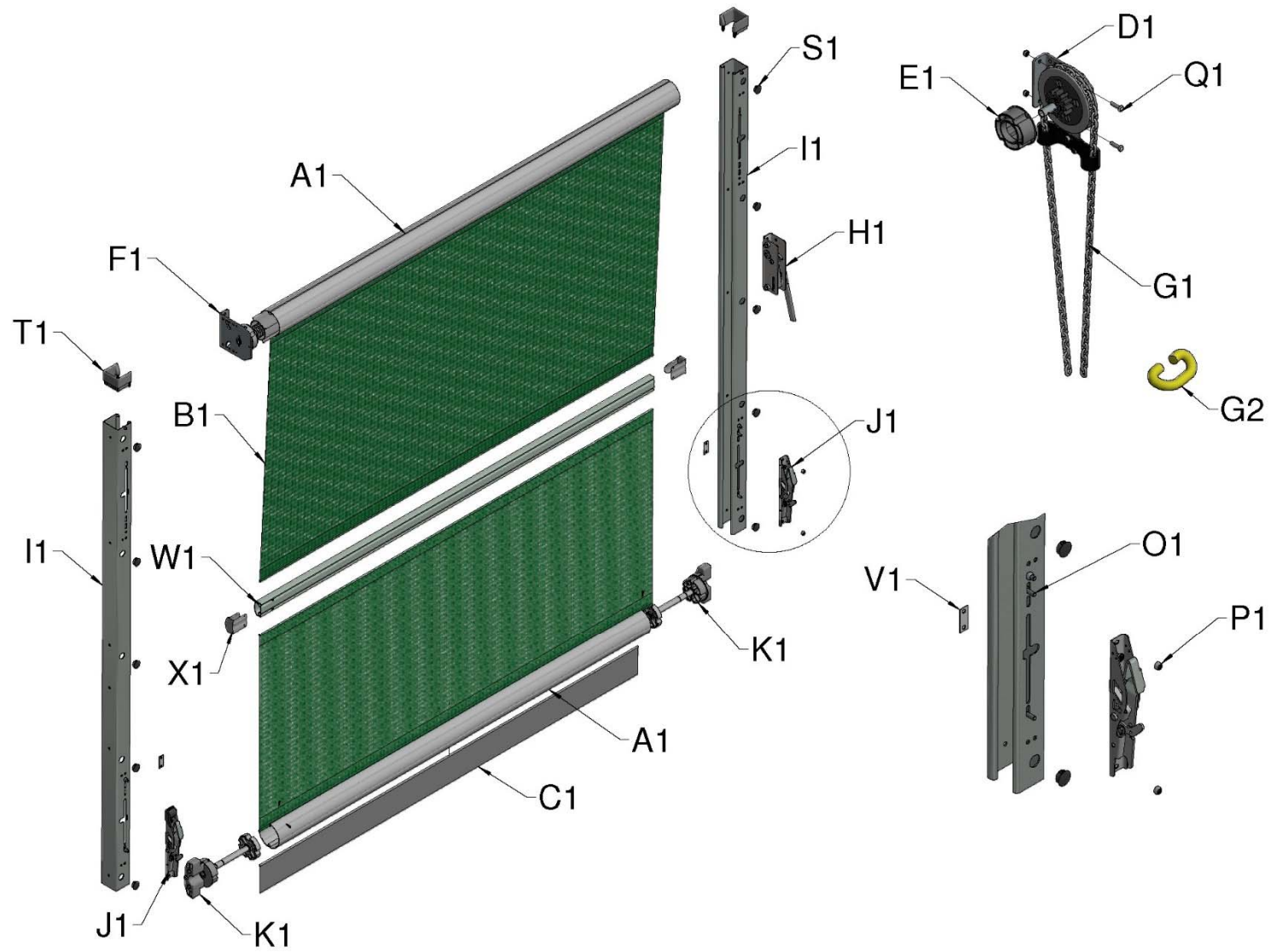

Figure 1, System Overview and Individual Components

**INTRODUCTION**

**Parts List**

REFERENCE:	QTY	PRODUCT DESCRIPTION
A1	2	Top and Bottom Tubes
B1	2/3	Fabric Panels
C1	1	Bottom Flap
D1	1	Drive Bracket
E1	1	Drive Collar
F1	1	Spring Assembly (Left-Hand Insertion Shown)
G1	1	Operating Chain
G2	1	Joining Link
H1	1	Chain Tensioner
I1	2	'C' Section Guide Rail
J1	2	Locking Catch Bracket
K1	2	Bottom Tube Insert
L1	4/6	6mm Nylon Insert for Bottom Flap (not shown)
M1	4	M4 x 19 Self Drilling Screws for Fixing Screen
N1	12	M8 x 30 bolts for Fixing Brackets to a Steel Building
O1	4	M8 x 20 Hex Bolts to Fix Locking Catch Brackets
P1	12	M8 Nylocs
Q1	*	M8 Washers
R1	1	140 x 45mm Yellow Template (not shown)
S1	22	Guide Rail Plug
T1	1 pr	Guide
U1	2	M6 x 12 Hex bolt and Nyloc Nut
V1	2	Locking Catch Adjuster Stop
W1	1/2	Windbar
X1	2/4	Windbar Protection Cap
Y1	8/12	M4 x 25 Self Drilling Screws for Fixing End Caps

\* Quantity dependent on door size

**Your Safety**

The larger doors will require a mechanical lift to mount the roller assembly onto the top brackets. The respective weights are given in the table below based on standard material. Add 5% to this figure for doors supplied with 'HP' fabric, and 15% for doors supplied with solid fabrics.

WIDTH	HEIGHT	
	3.1m	4.1m
2.5m	27kg	32kg
3.0m	30kg	36kg
3.5m	40kg	47kg
4.0m	43kg	51kg
4.5m	45kg	55kg
5.0m	48kg	59kg

GB

**Pre-Installation Check**

Figure 2 indicates space required to install your door, with additional information for mounting multiple doors in series.

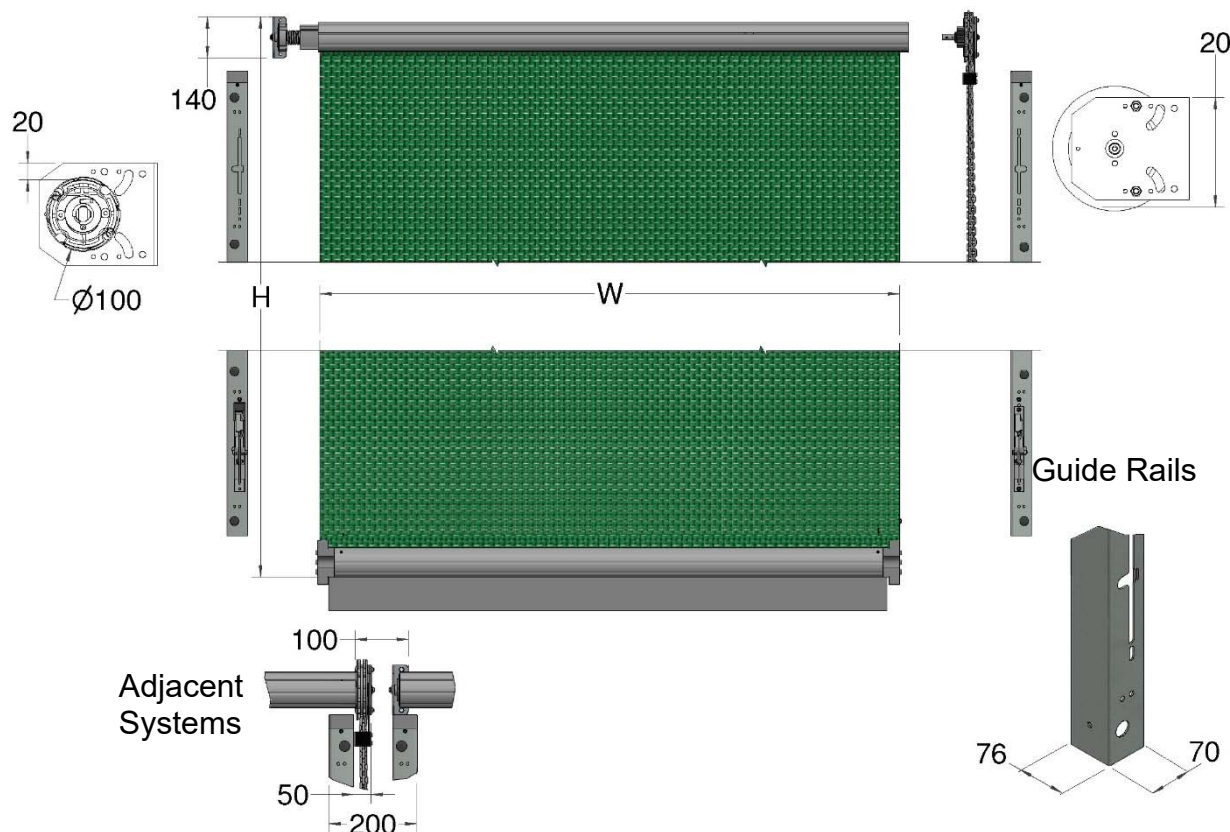

GB

Order Width (m)	Fabric Width (m)
2.5	2.5
3.0	3.0
3.5	3.5
4.0	4.0
4.5	4.5
5.0	5.0

Order Height (m)	Max Height (m)
3.1	3.10
4.1	4.10

Figure 2, Fitting Requirements

**CAUTION**

**CAUTION:** To safeguard against any danger points, the minimum height 'H' of any door is 2.5m.

In the event of door failure, the door must not form the only means of exit from the building to which it is fitted.

**Wind Loadings**

The structure to which the door is fitted needs to be of adequate strength to resist the following wind loads.

Wind Speed (km/hr)	Wind Load (N)*	Wind Load (Kg)*
70 km/hr	= W x H x 233	= W x H x 24
100 km/hr	= W x H x 481	= W x H x 49
140km/hr	= W x H x 933	= W x H x 95

GB

*\*No allowance made for safety margins*

**Right or Left Hand Drive**

Your door will be supplied in accordance with the drive orientation specified when ordered. The images and text in these Instructions are base on a door with a right-hand drive, if you have ordered a left-hand drive then reverse the references. To change drive orientation on-site refer to Appendix I for details of spring conversion.

**Installer Competence**

The installer should be able to demonstrate the required level of competence via evidence of installing similar products or formal training. If competence cannot be proven then they should not be allowed to install the product.

**Product Description**

This door is a manually operated vertically moving rolling door comprising of a flexible curtain capable of being rolled and for which the main intended uses are giving safe access for goods and vehicles accompanied or driven by persons.

**Items Required By The Installer**

Standard tool kit including:

- Electric drill
- Angle grinder
- Sharp pair of scissors or knife
- Spirit Level
- Bolts for fixing the brackets to steel up to 12mm thick are supplied, if fixing to a wooden or concrete building you will require eight M8 fixings to fasten the top brackets and M8 fixings for the guide rail at 1m centres.

GB

**Key Instructions**



**CAUTION:** Potentially hazardous situation: must be avoided otherwise injuries may result.



**ATTENTION:** Observe the given instructions otherwise the product or adjacent items may be damaged

**NOTE:** Helpful comments and information to assist in installation or use of your product

**NOTE:** Before starting the installation it is advisable to read these instructions completely to understand the procedure and keep the instructions supplied for reference purposes.

**NOTE:** Colour versions of the installation instructions can be downloaded from our website:

[www.galebreaker.com](http://www.galebreaker.com)

**INSTALLATION**

**Door Assembly**

1. Check the contents of your door against the parts list using Figure 1. Do not let the screen material come into contact with any sharp objects or edges.
2. Using the yellow template (R1), drill M8 holes for the two top brackets. The maximum recommended overlap for Post Fixing (Drive End) = 150mm, Post Fixing (Free End) = 100mm and for lintel fixing = 175mm (Figure 3). It is essential that the top brackets are level and upright.

GB

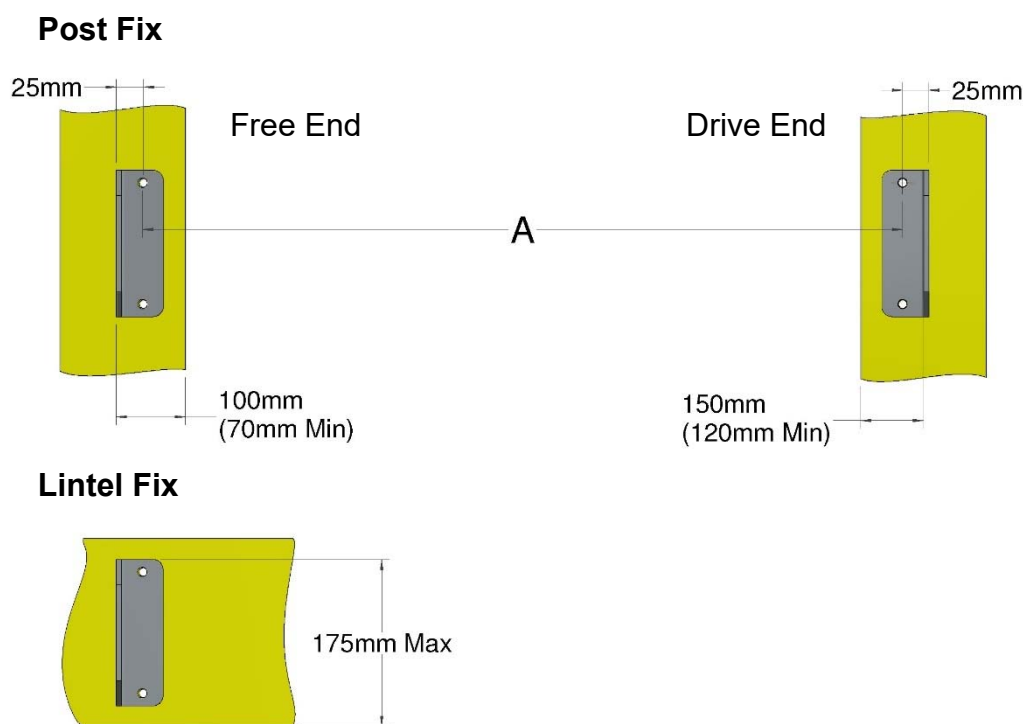

Figure 3, Top Bracket Positioning

	<p><b>ATTENTION:</b> To prevent abrasion and material fray, maximum overlap between bracket face and edge of fixing must not exceed that shown in Figure 3. If overlap exceeds these recommendations ensure there are no sharp objects on the building to damage the material, and rough surfaces such as concrete is protected with PVC strip or similar.</p>
--	--

- Slide drive collar (E1) onto chain wheel gear attached to drive bracket (D1) and bolt assembly to the building with M8 fixings supplied, Figure 4a. The orientation of the drive bracket is as specified when you ordered your door, see Figure 4b and 4c, the spring is situated on the opposite side. If you wish to fit the drive bracket to the opposite side to that ordered, refer to instructions in Appendix I.

GB

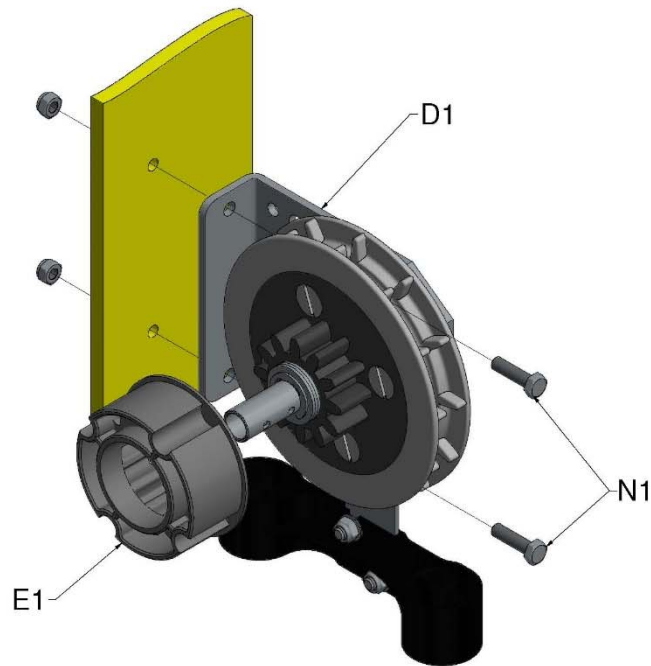



Figure 4a, Attach Drive Bracket to Building

 <p><b>CAUTION</b></p>	<p><b>CAUTION: Only use M8 bolts or greater to fit the door. Ensure all brackets are securely fastened to the building. Failure of these fixings will result in your door falling off the building, potentially injuring operators and bystanders.</b></p>
---	--

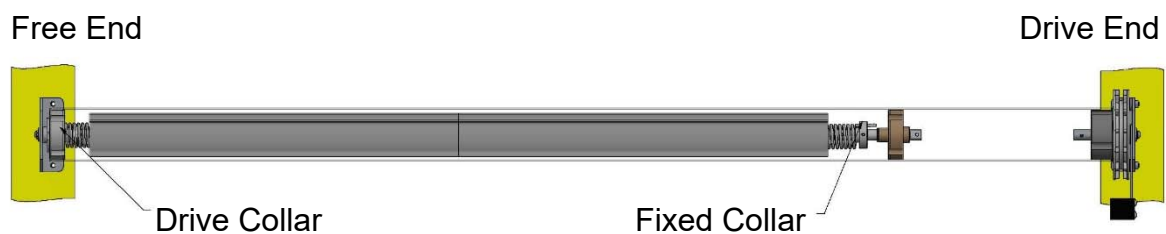

Figure 4b, RH Door, Drive Bracket on the Right



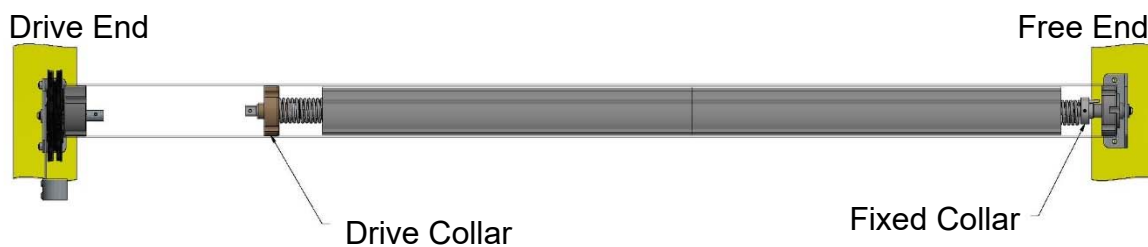

Figure 4c, LH Door, Drive Bracket on the Left

GB

**ATTENTION:** It is vital that the spring is fitted in accordance with these instructions; otherwise it will suffer terminal damage, for which Galebreaker is not liable.

**NOTE:** If you wish to fit the spring to the opposite side to that ordered, refer to instructions in Appendix I.

4. Cutting lengths

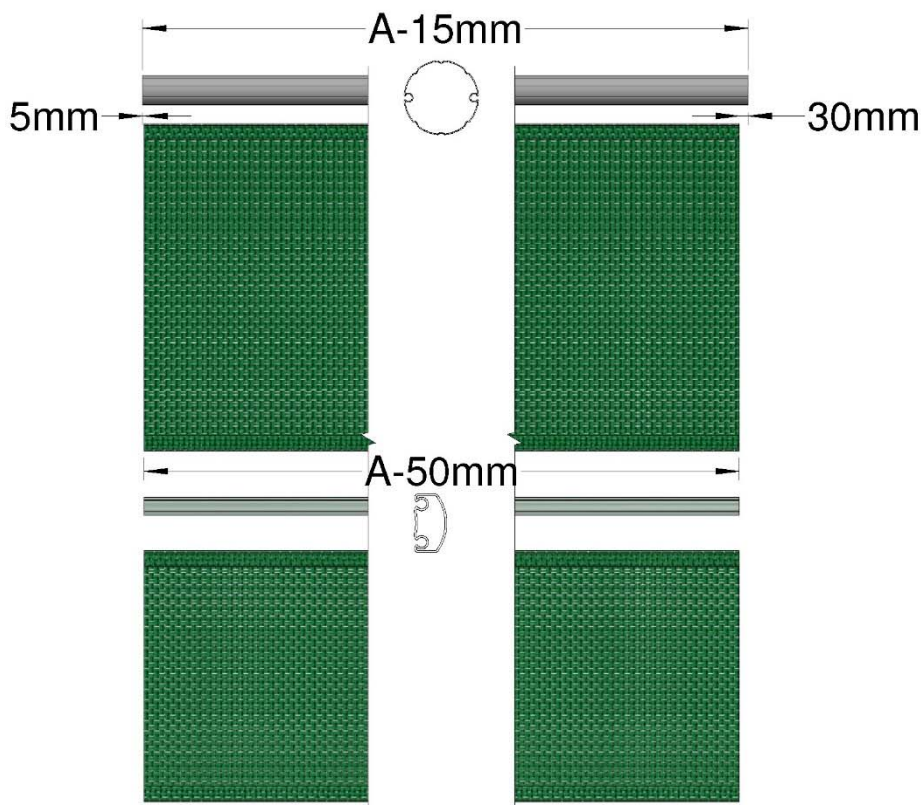

Figure 5, Standard Cutting Lengths of Tubes and Fabric

- Top Tube = Distance between centre of drilled holes -15mm (-0.015m)
- Screen + Windbar = Distance between centre of drilled holes -50mm (-0.050m)  
(35mm shorter than top tube)

5. Push the Flute Guide Insert over the end of the flute in the tube to protect the fabric sheet as it is being fitted.

**NOTE:** To ease the insertion of the fabric panels into the windbars ensure all metal burrs are removed, and use a lubricant such as light oil or washing-up liquid.

GB

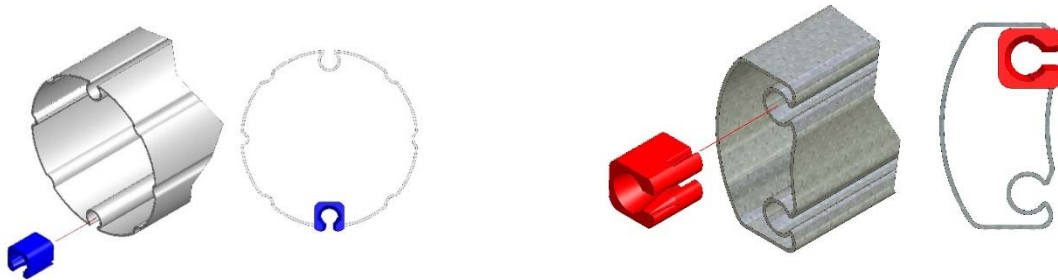

6. Slide the nylon insert (found inside the windbars) into the pocket of the fabric and cut to suit, slide the fabric panels and windbars onto the top tube assembly. When the fabric is inserted remove the Flute Guide Insert form the end of the flute.

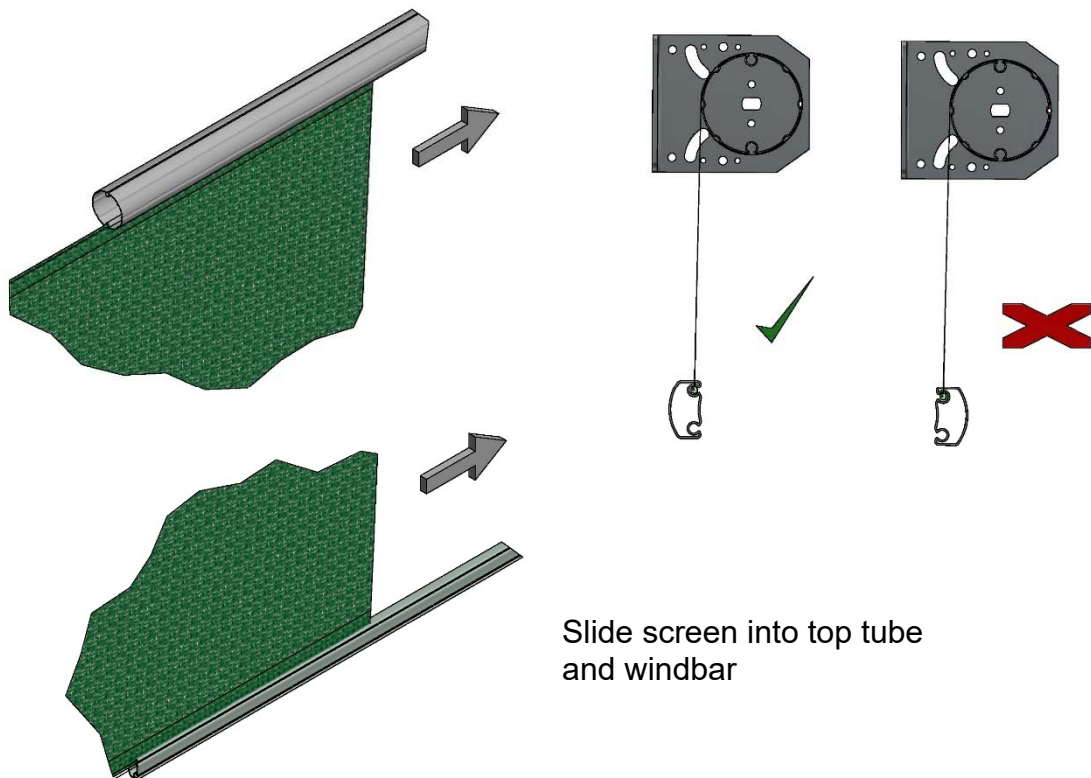
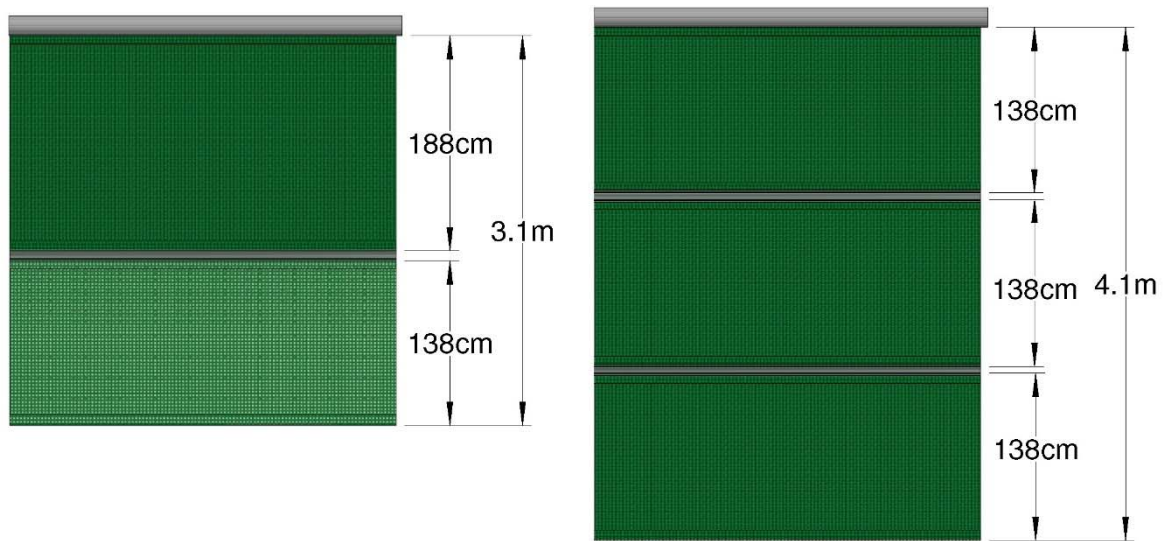

Figure 6a, Slide fabric onto top tube

Ensure that the panels go in the correct position, refer to Figure 6b.



GB

Figure 6b, Fabric Panel Layout

Secure the screen in each corner using the 25mm self-drilling screws supplied (Z1), ensuring the windbar protection caps (L1) are fixed at the same time. To prevent damage to the caps do not over tighten the screws. It is important to tension sheet sideways before fixing to remove creases (Figure 7). Do not secure the fabric to the top tube at this point.

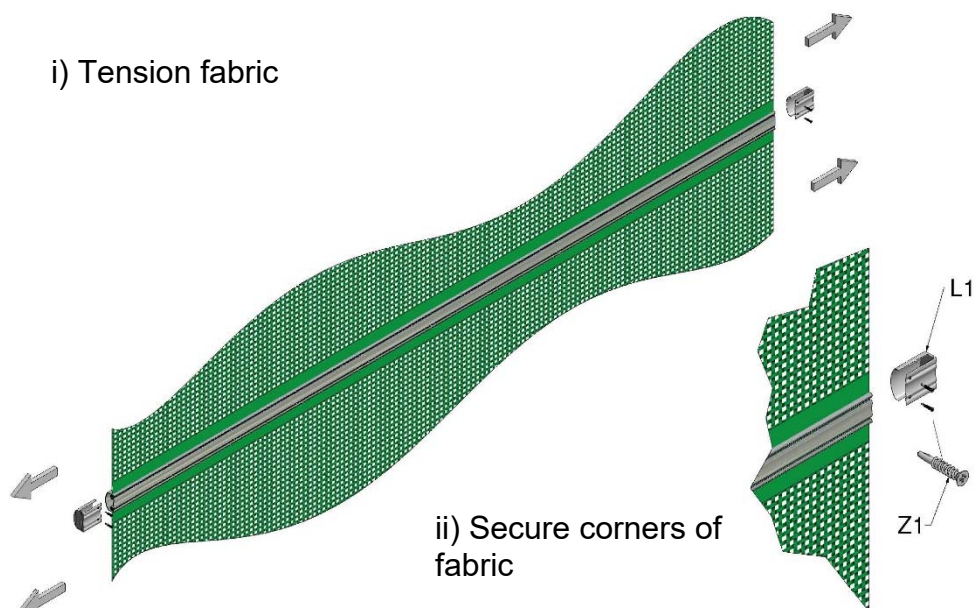
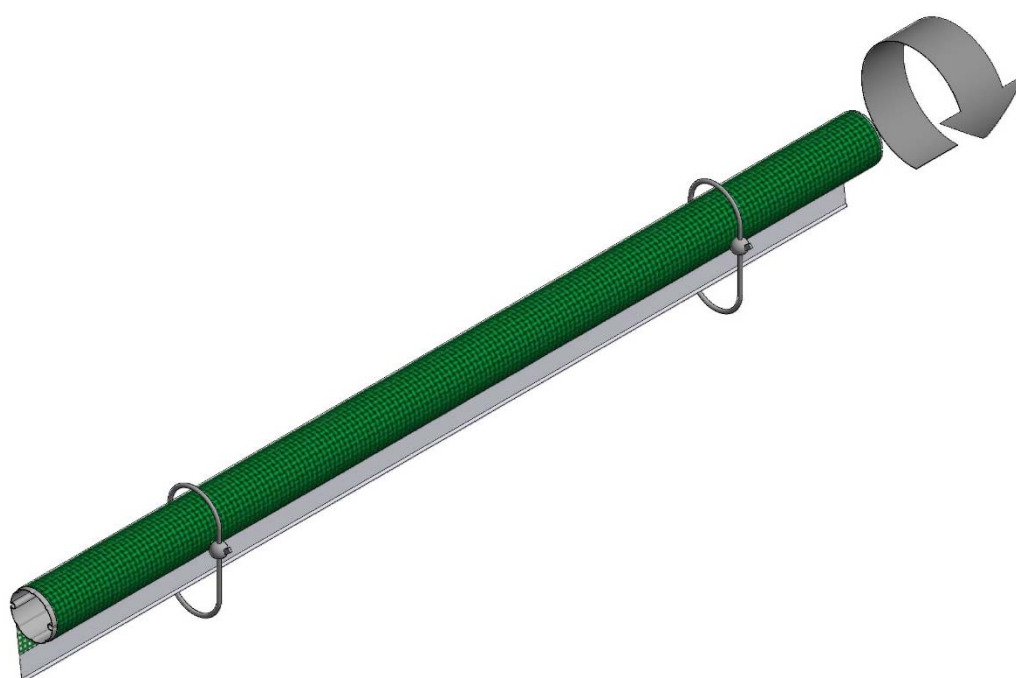

Figure 7, Securing Fabric

Roll the windbars and fabric panels onto the top tube. It is important that when the door is hung the fabric should come off the back of the top tube, between the tube and the building. Tie up the roller assembly (figure 8)



GB

*Figure 8, Fabric Attached to Top Tube and Rolled Up*

- Slide spring assembly (F1) into the top tube (A1). Lift assembly into position, checking that the fabric rolls off the back of the top tube (Figure 9).

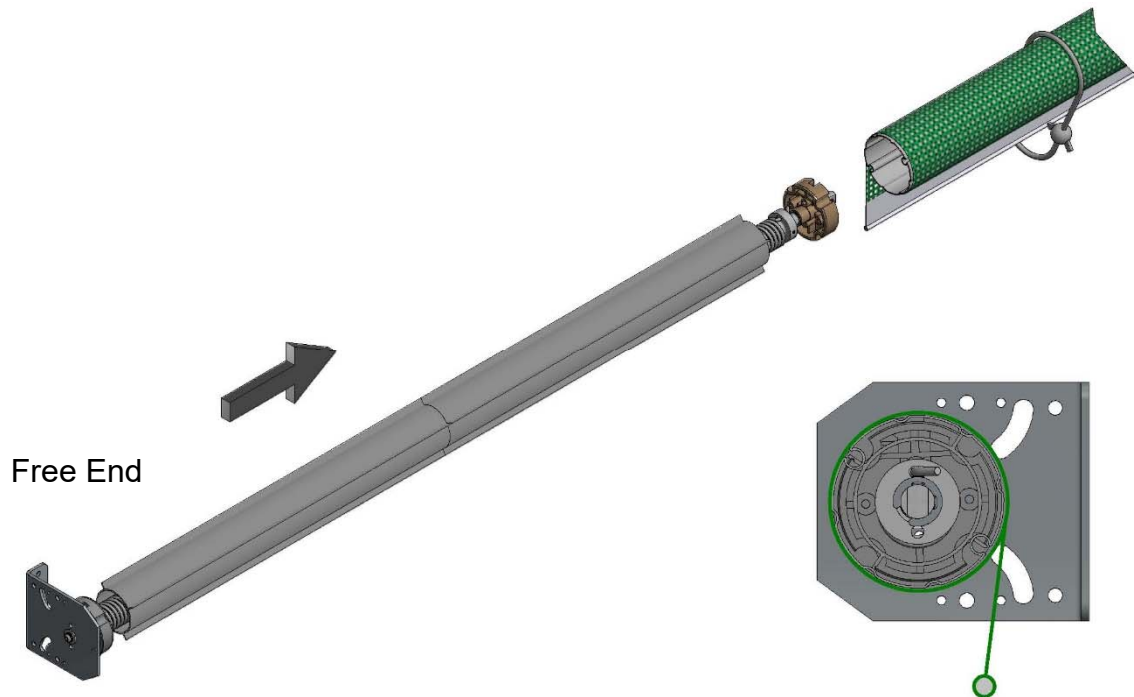

GB

Figure 9, Insert Spring Assembly into Top Tube

Locate top tube on the drive collar and bolt the free end (spring) bracket to building with M8 fixings supplied (Figure 10). If optional cowling has been supplied, fit cowling brackets at this stage, see Point 17.

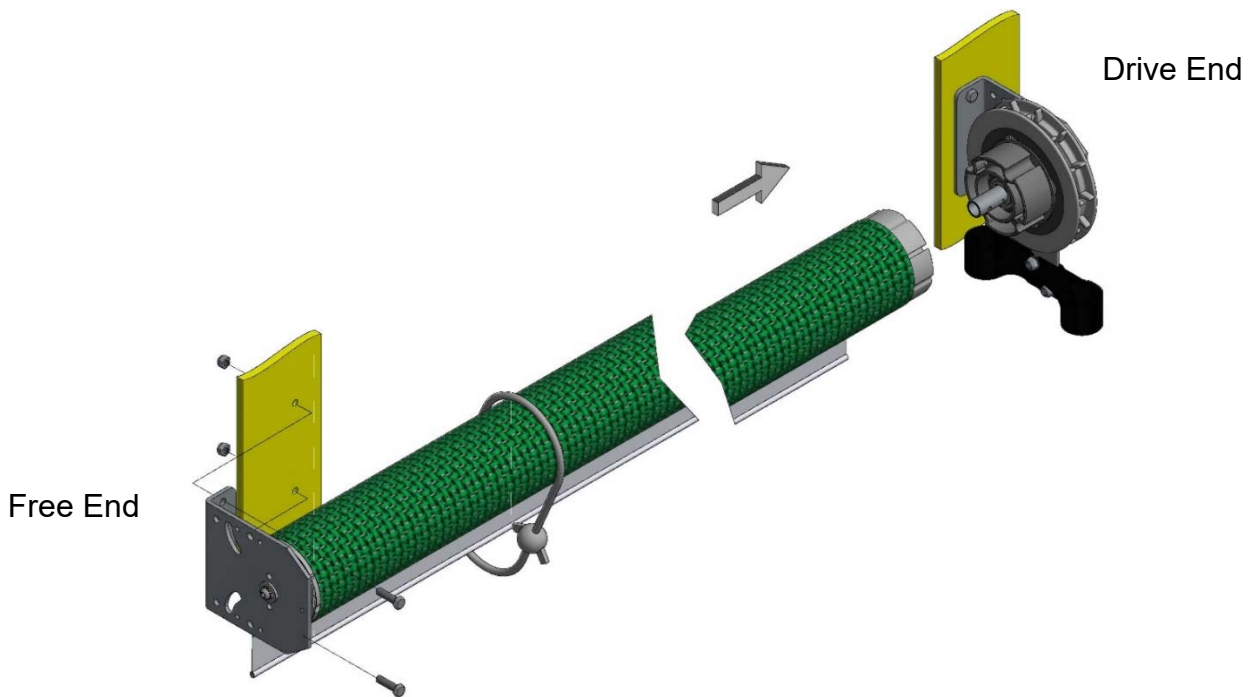



Figure 10, Bolt Free End Bracket to Building



**ATTENTION:** Check the material rolls off the back of the top tube and the spring is in correct position. It is vital these instructions are followed correctly; otherwise the spring will be damaged.

GB

8. Measure the height from the underside of the top bracket to the floor and equally cut the guiderails as per figure 11. Make sure that the un-cut end with the slot and holes is at the bottom ready to accept the locking catches. Fit the pair of guides into the top of the guide rails (cut end) and secure with the M6x12 bolt and nut (U1) in the front face, Figure 11.

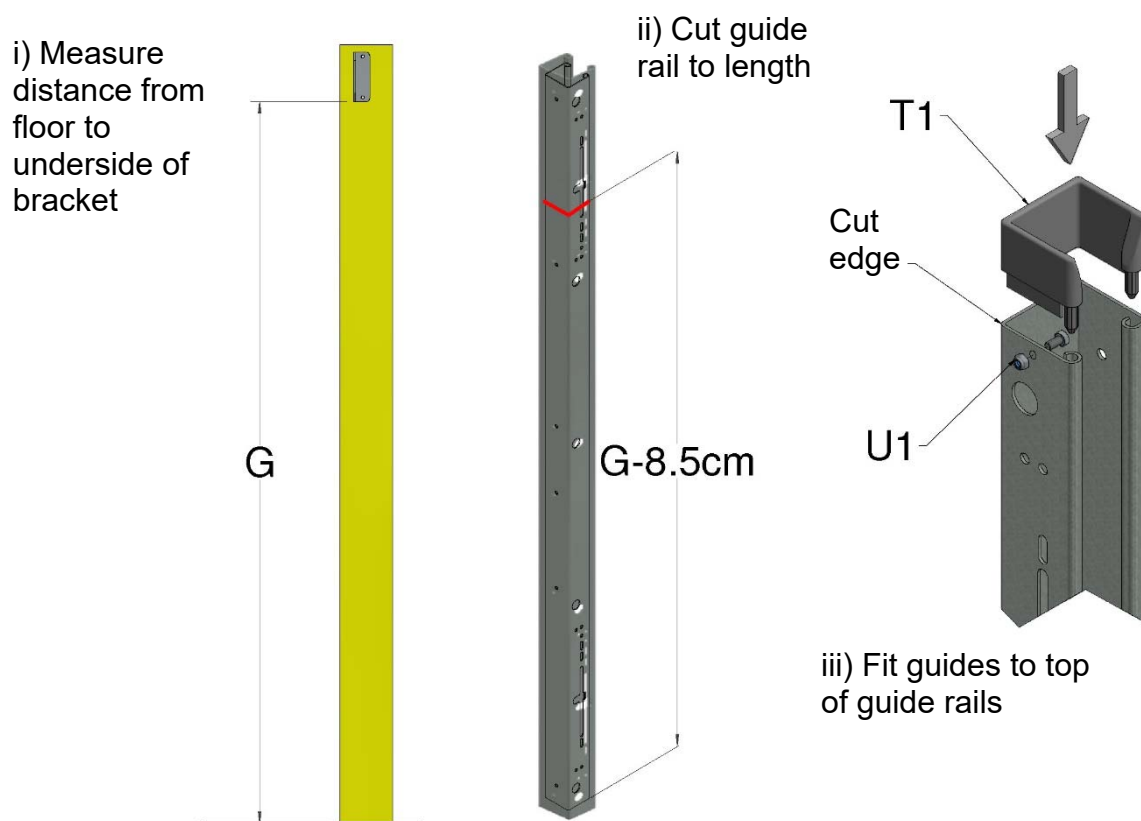

Figure 11, Cutting Lengths of Guide Rails

9. The Guide Rails are to be positioned so that the Free End Guide Rail is flush with the spring bracket (F1) and the Drive End Guide Rail is offset by 50mm from the drive bracket (D1), as shown in Figure 12a. The cut ends of guide rails are to be positioned next to wall brackets.

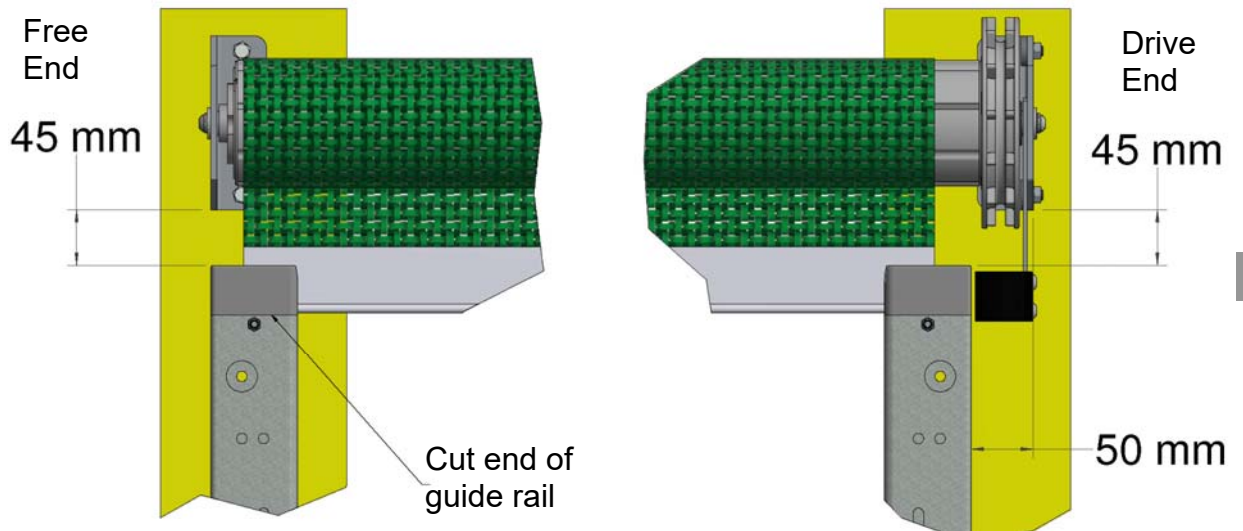

Figure 12a, Guide Rail Positioning

Fit the guide rails to the building with M8 fixings at 500mm centres, see Figure 12b for the standard installation layout.

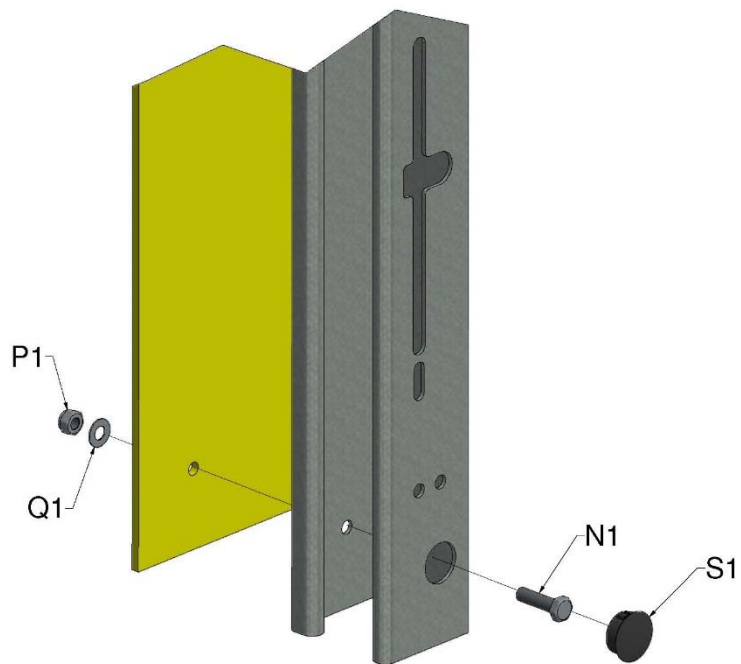

Figure 12b, Bolting of Guide Rails to Wall

10. Bolt the locking catches (J1) to the pre-punched slots at the base of the guide rails using the M8x20 set screws (O1) and lock nuts supplied (P1). Pass the upper catch screws through the locking catch stop plate (V1) fitted on the inside of the guide rail to prevent the catch sliding up the pre-punched slots. Ensure the swinging arm of the locking catch clears the long slot in the guide rail. Fit caps to the top of locking catches.

GB

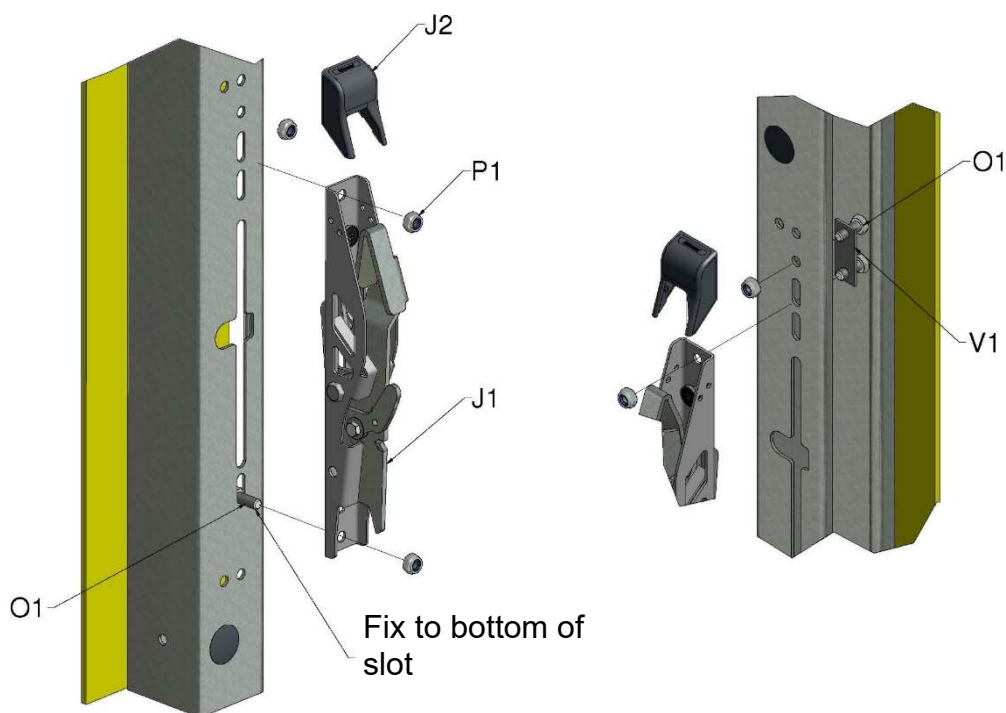
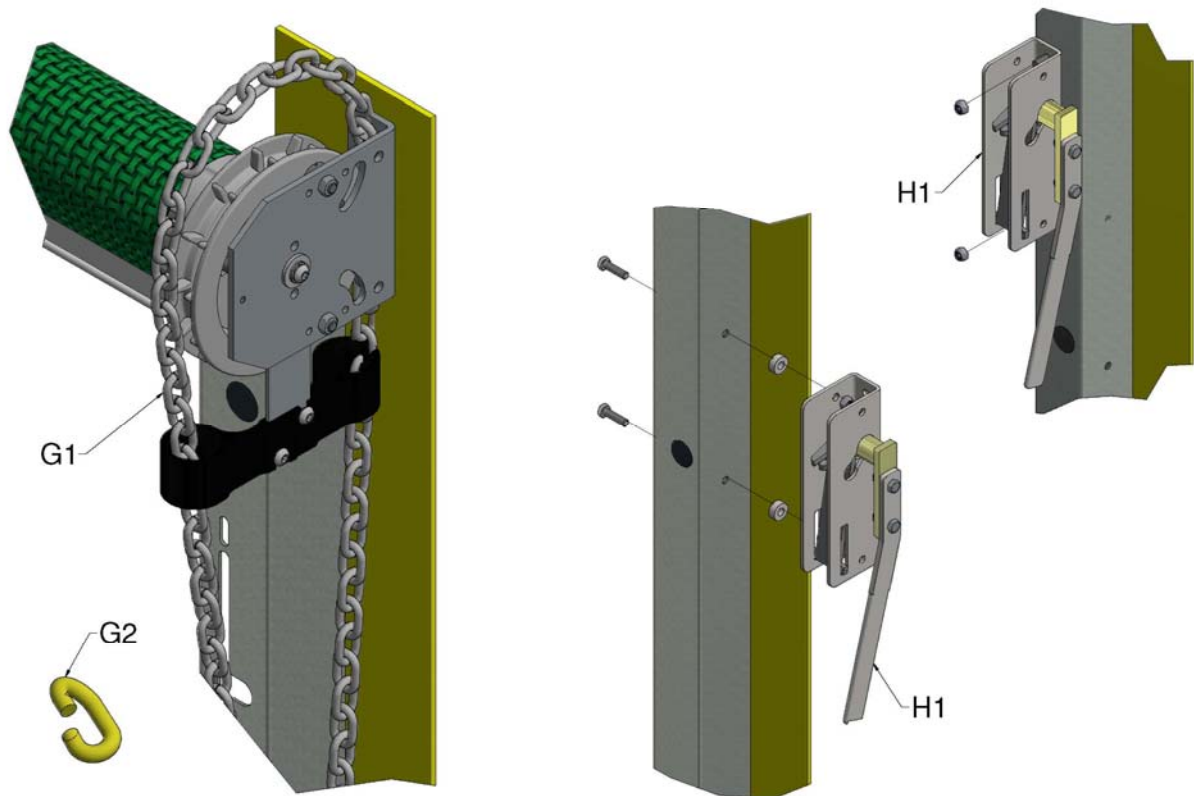

Figure 13, Bolting Locking Catches to Guide Rail

11. Feed the operating chain (G1) around the chain wheel, through the chain guide and trim to length if required. Make chain into a continuous loop by joining the two ends with the Joining Link (G2). After closing, file away any sharp edges to ensure the chain does not injure operators; it is not necessary to weld the link shut. Install the chain tensioner (H1) to the guide rail or building with two M8 fixings. The height of the chain tensioner depends upon your installation but is typically 1.5m high.





GB

Figure 14, Installation of Operating Chain and Chain Tensioner

**NOTE:** If you wish to fit the chain tensioner to the Left Hand side, refer to instructions in Appendix II.

12. Pre-tension the spring mechanism by rotating the roller assembly in the direction shown in Figure 15, this is done by pulling down on the inner chain as shown. The number of pre-tension turns is given in the table below. When the required number of turns has been reached, lock the operating chain into the chain tensioner.

GB

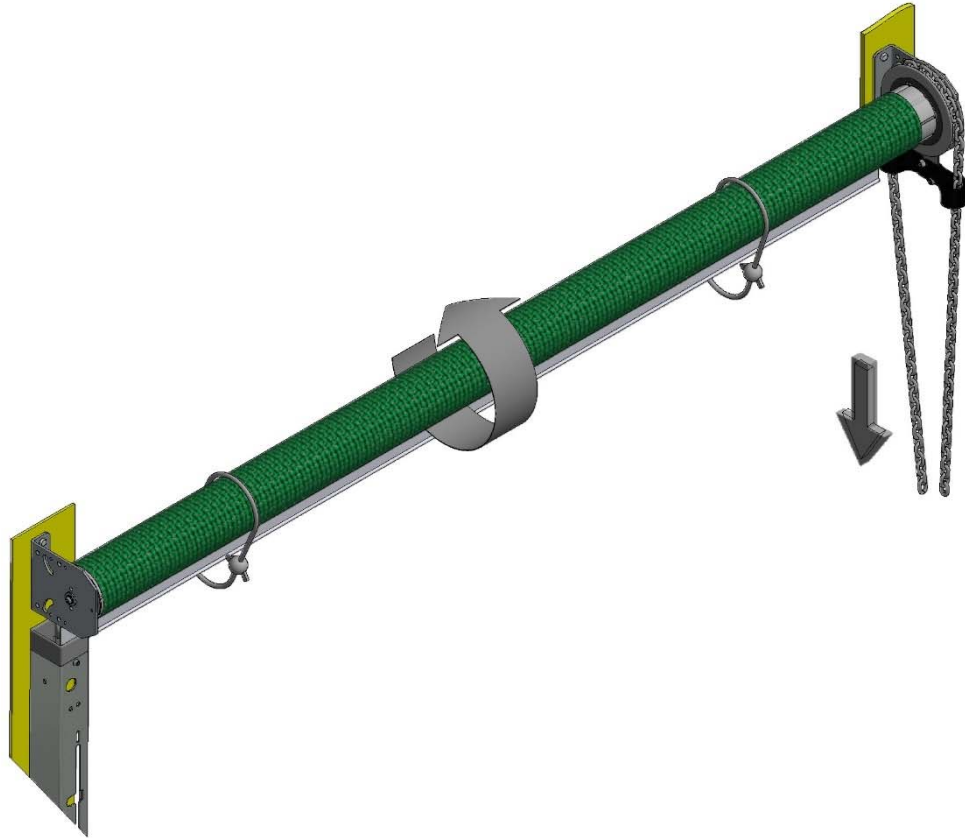



Figure 15, Tensioning of Spring

WIDTH	HEIGHT & No. OF TURNS	
	3.1m	4.1m
2.5m	8 (2.32m spring	9
3.0m	10 with red tag)	12
3.5m	11	13
4.0m	9 (2.97m spring	10
4.5m	11 with blue tag)	13
5.0m	12	15

**NOTE: Additional pre-tension: Add one extra for doors supplied with 'HP' fabric, and two extra for doors supplied with solid fabrics.**

 **ATTENTION: To prevent spring damage, do not over-tension.**

13. Cutting bottom tube and flap:

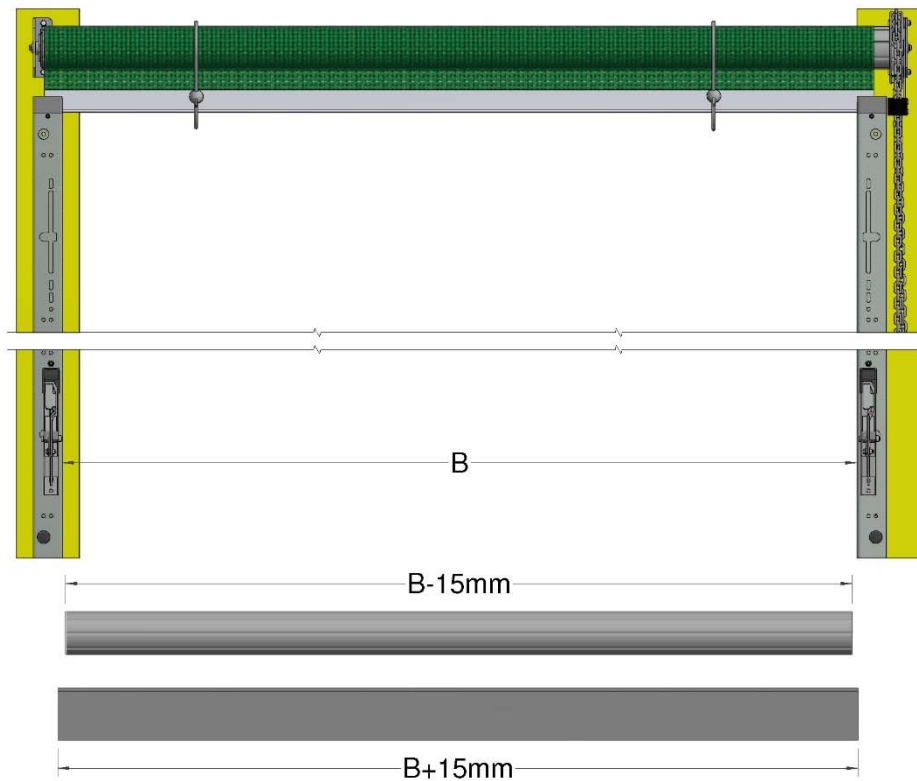

Figure 16, Cutting Length of Bottom Tube, Insert and Flap

- Bottom tube = gap between inner faces of guide rails - 15mm (-0.015m)
- Insert = gap between inner faces of guide rails +15mm (+0.015m)
- Bottom Flap = gap between inner faces of guide rails +15mm (+0.015m)

14. Slide nylon insert (L1) into the pocket of the flap (C1) and slide flap into bottom flute, Figure 17.

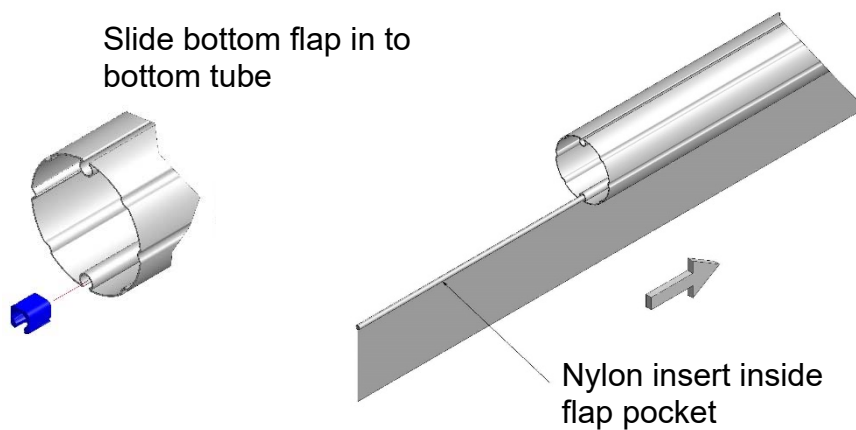

Figure 17, Flap Attached to Bottom Tube

**Attaching Bottom Tube**

- Untie the top tube assembly and lower the door. Pull the lower panel outside the guide rails and slide on the bottom tube, Figure 18a, and trim fabric as shown in Figure 18b. Push the inserts (K1) into the tube and fix using the M4x19mm self-drilling screws supplied (M1).

GB

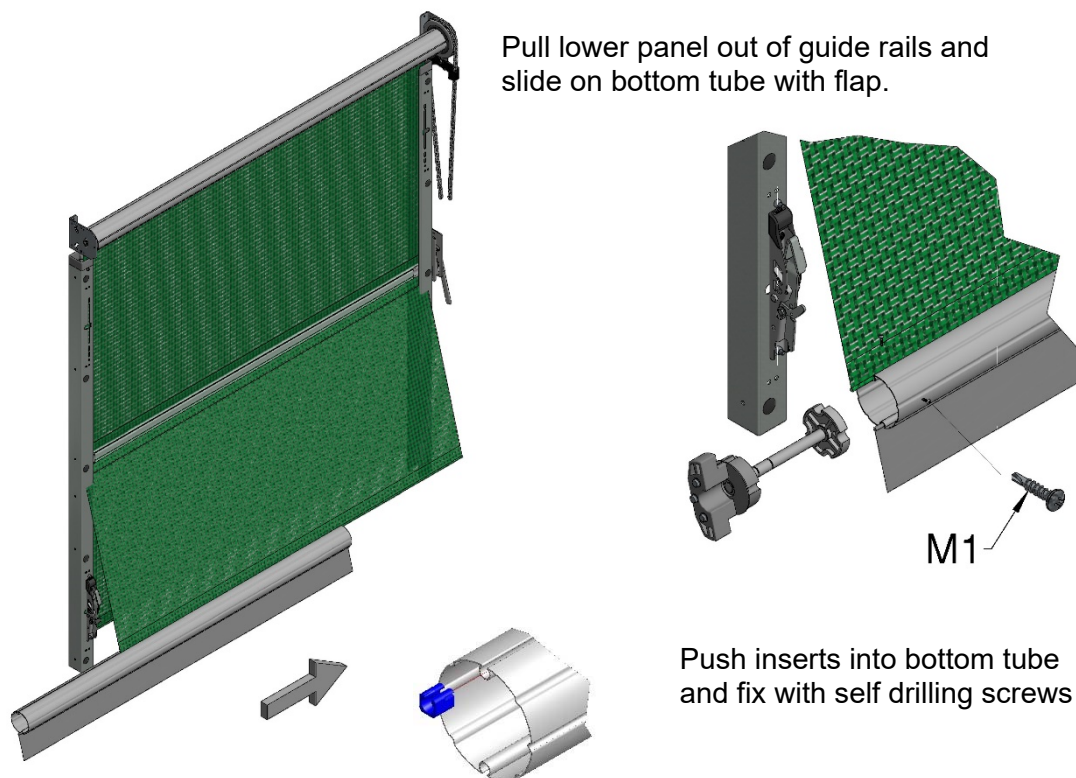

Figure 18a, Attaching Bottom Tube

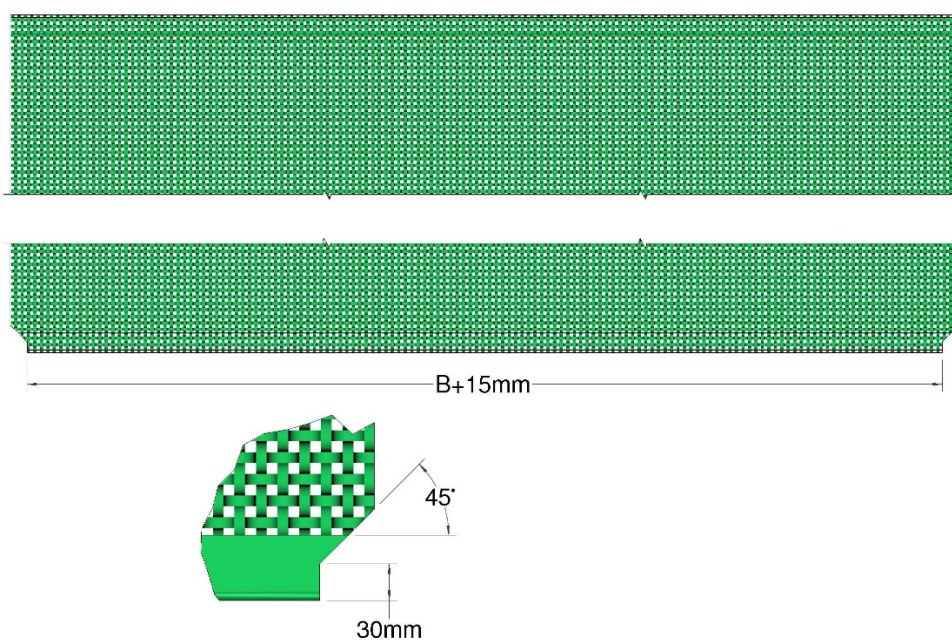

Figure 18b, Trimming Sheet

**Securing Fabric**

16. Centralise the screen and secure each corner using 19mm self-drilling screws supplied (M1). It is important to tension sheet sideways before fixing to remove creases as shown in Figure 19. Insert one end of the bottom tube into the guide rail, lift and insert the other end into the opposite guide rail.

GB

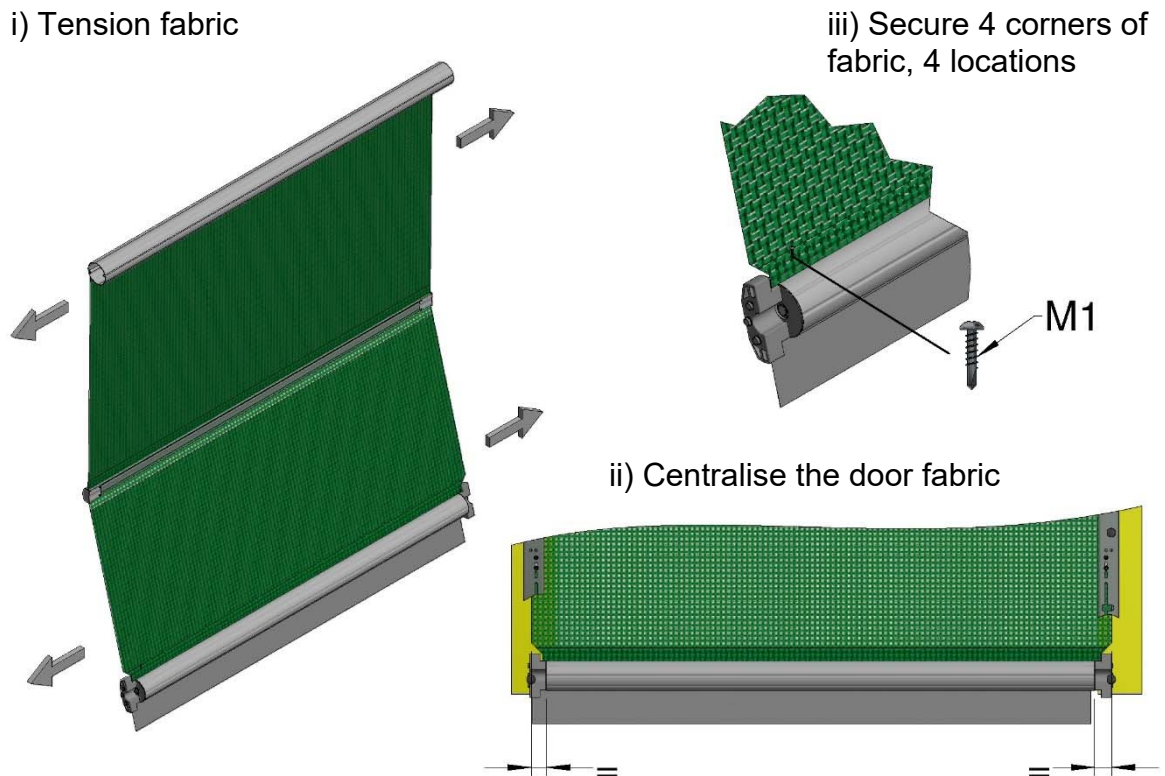
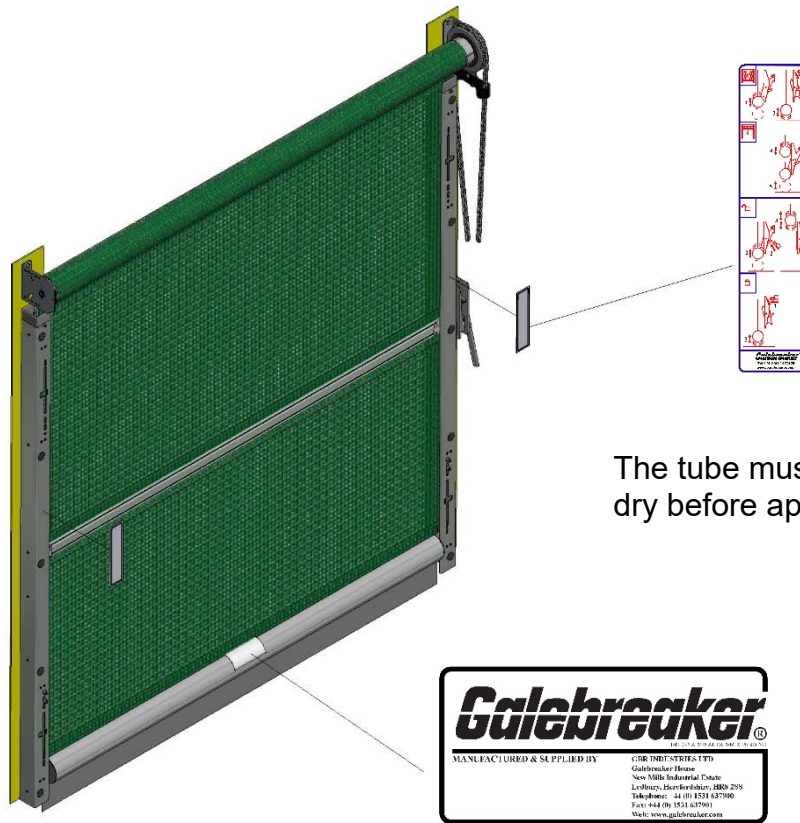

Figure 19, Centralising Screen

17. Finally adjust the operating chain such that when the door is lowered the joining link is situated below the chain tensioner. During high winds there is considerable force on the chain between the wheel and the chain tensioner and there is the risk that the joint would fail in these circumstances.

18. Attach the locking catch instruction labels to the front of the guide rails at a convenient height, typically 1.5m from the ground. Attach the company detail label centrally to the front of the bottom tube.



GB

The tube must be clean and dry before applying the label



Figure 20, Attaching Labels

**Installing Door Cowling**

19. Door Cowling

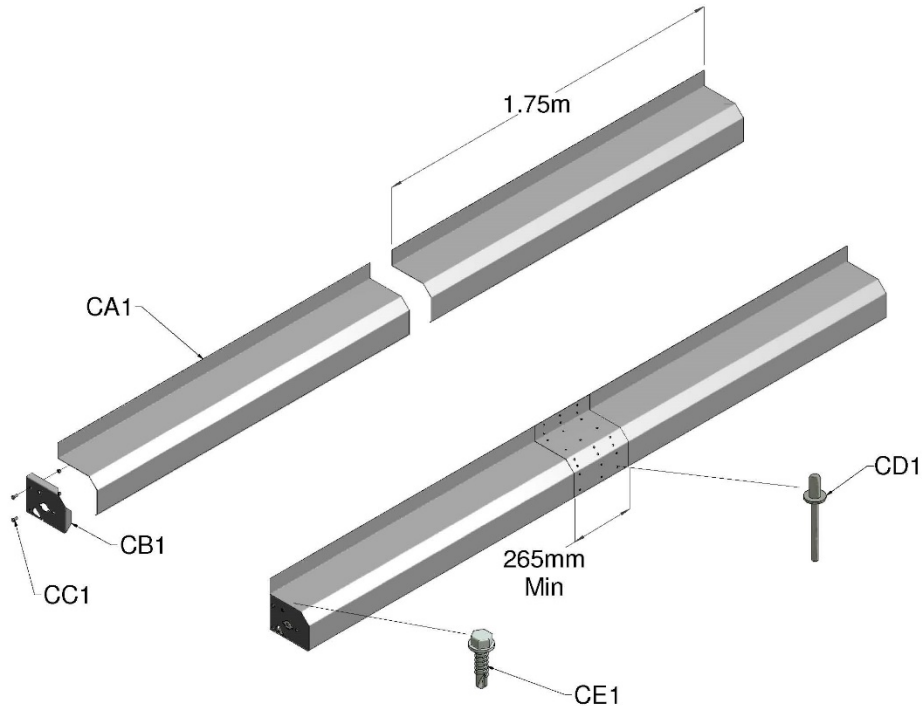

GB

REF:	QTY	PART DESCRIPTION
CA1	*	1.75M Lengths of Cowling
CB1	1 pr	Cowling End
CC1	2	M8x20 Hex bolt and Nut
CD1	24	M4.8 x 8 St Steel Rivets / per join
CE1	6	M5.5 x 19 Self Drilling Screws
CF1	1	5mm Drill for rivets (not shown)

Figure 21, Door Cowling Assembly

- C1. Fit the cowling ends (CB1) to the outsides of the drive & free end brackets using the M8x20 hex bolts and nuts.
- C2. Join the main cowling (CA1) with a minimum overlap of 265mm, using the M4.8 x 8 rivets, (CD1) 6 in each of the four faces. Fix the cowling to the cowling ends using the M5.5 x 19 self-drilling screws (CE1), three per side, Figure 21.

**NOTE: The Cowling is self-supporting and does not require intermediate brackets.**

20. UKCA Marking Products under Construction Products Regulation

**It is the responsibility of the installer to check that the installation conforms to the specific safety features detailed in the Manufacturer’s Installation Instructions, to issue the Declaration of Conformity and mark a product under the Construction Products Regulation 305/2011.** To do this you will require the following which should be delivered with the product:

GB

- 1) This set of Installation Instructions (*operating and maintenance instructions*)
- 2) Maintenance Log Book, (*including Installation Checklist and Customer Declaration of Conformity*)
- 3) 1 x Declaration of Conformity (Installer Copy) – *to be completed*
- 4) A UKCA Label

**When UKCA marking a Galebreaker product, it is vital to follow the steps outlined below:**

- a) Install the product as per instructions, with no adaptations or modifications and complete of the *Health and Safety Checklist* in the Maintenance Log Book.
- b) Complete the two ‘Declarations of Conformity’ using the following:
  - **Model Type:** As shown on UKCA Label
  - **Serial Number:** As shown on UKCA Label
  - **Installation Company:** Your company name
  - **Date Installed:** Date Installed
  - **Declaration made by:** Responsible Person
  - **Declaration and Instructions received by:** Customer’s Signature
- c) Fix the supplied UKCA label to the bottom tube. The label should be accessible / visible. Where the serial number does not incorporate the door size, add the Product width and Product height to the end of serial number using a permanent marker pen. i.e. the full serial number should read

Serial Number:     1234 /     AD-CPM             W    X    H

[W] Product Width (m)

[H] Product Height (m)



- d) Your customer must be given a copy of the completed 'Maintenance Log Book' along with the 'Installation Instructions' supplied by Galebreaker. These should be stored adjacent to the door controls for reference purposes.
- e) Finally, ask your customer to sign the 'Declaration of Conformity' (Installer Copy). This important document must be filed back at the office of the installer for future reference.

GB



Figure 22, UKCA Label Location

**YOUR DOOR IS NOW READY TO USE**

**OPERATION AND MAINTENANCE**

***How to use your door***

- Windspeed less than 32kph / 20mph

In light wind conditions, the locking catch can be disabled. If the Locking Catch (J1) is active, disable it by pushing on the disengagement lever, Figure 23. Pull the operating chain to open and close your door, insert the outer chain into the chain tensioner to hold the door at any level.

GB

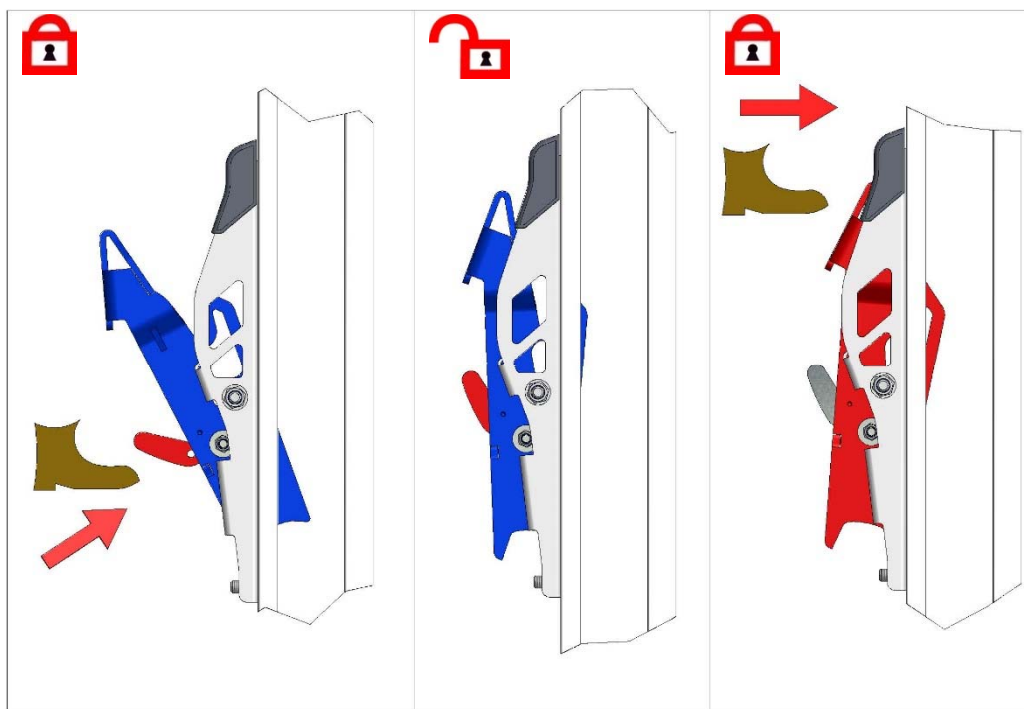

*Figure 23, Engaging and Disengaging Locking Catch*

	<p><b>CAUTION:</b> The chain must be secured using the chain tensioner to prevent the door movement</p>
---	---

- Windspeed over 32kph / 20mph

	<p><b>ATTENTION:</b> It is vital that a closed door is secured via the locking catches when the wind speed is above 32kph / 20mph</p>
---	---

From Open: If the Locking catch (J1) is disabled push on the top section of the locking plate for re-activation, Figure 24i. Pull on the outer chain to close your door and when the bottom tube passes the locking catch (Figure 24ii) backwind the door until the bottom tube engages with the locking catch (Figure 24iii). Raise the handle of the chain tensioner and insert the nearest link of the outer chain into the hook slot. Push the lever fully down to tension the door.

GB

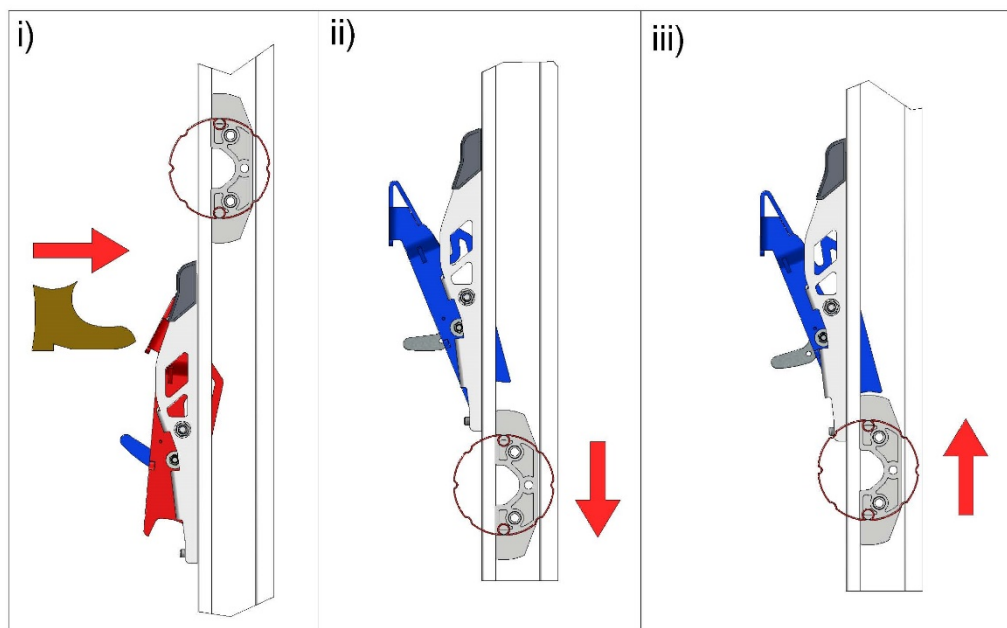

Figure 24, Locking Door Closed

From Closed: Pull on the inner chain to lower the door at least 10mm, open both locking catches by pushing on the top section of the locking plate (Figure 25). Pull on the outer chain to fully open the door and insert the outer chain into the chain tensioner.

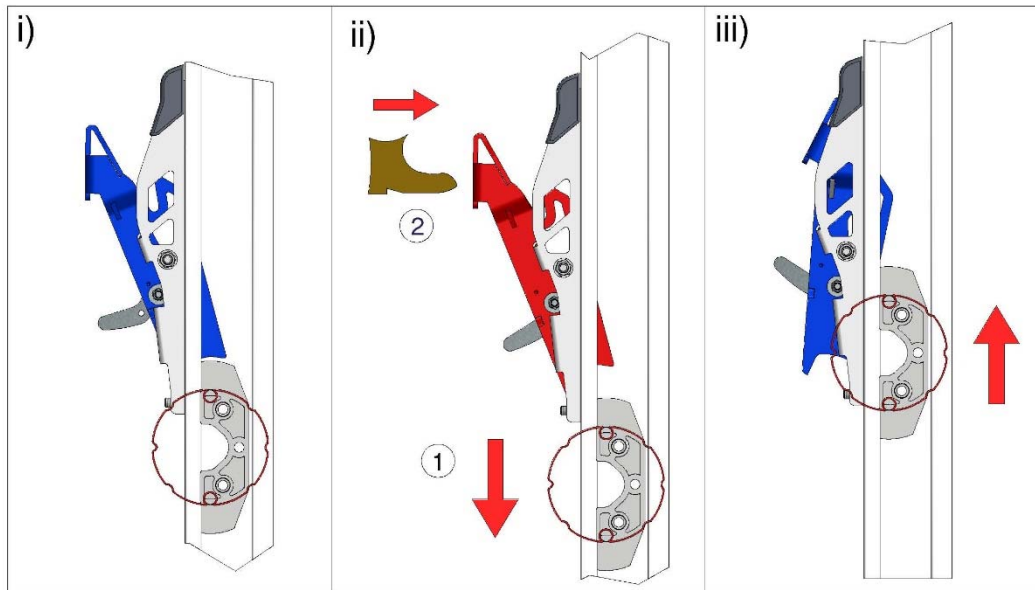

Figure 25, Opening Door From Locked Position



**CAUTION:** The chain must be secured using the chain tensioner to prevent the door movement.

**Important Safety Information**

- This door must only be operated by users familiar with its operation.
- When operating the door do not place fingers near the guide rails or other moving parts at any time.
- The person operating the door must have the door in sight at all times during its operation.
- Do not permit children to play with the door.
- Do not modify or attach any objects to the door as this may cause damage and/or injury.
- Operate the door only when properly adjusted and free from obstructions.
- Should the door become difficult to operate or inoperable, consult your local dealer. Repairs should only be carried out by competent personnel.

**Wind Load Resistance:**

**Mesh 75% Solid**

**Up to 25sqm = Class 5**

**Solid Material**

**Up to 25sqm = Class 5**

GB

**Maintenance of your door**

- Check annually for corrosion of the supporting bolts fixing the product to the building, the bolt holding the shaft into the top brackets and the blind in general. Replace suspect items to ensure it is safe for operators and bystanders alike
- The spring has a design life of 10,000 operations, which equates to using the door approximately 3 times a day for 10years. After 10 years we recommend a replacement spring be fitted, or following the dismantling instructions given below remove the spring annually to ensure it has not broken.
- If the chain tensioner becomes stiff to operate apply a thin layer of grease to either end of the pivot shaft and to the outer walls of the two slots.
- Annually clean the magnet on the locking catches to remove surface dirt.
- Should Screen material be damaged, repair with special repair kit (code SPS-99) available from your Galebreaker dealer, importer or head office.

GB

**How to dismantle your door**

Follow the installation instructions in reverse order. In particular ensure all spring tension is removed before unbolting the top brackets to remove the roller assembly and recoil spring.



**CAUTION:** To prevent injury ensure spring has no residual tension before removal.

**NOTE:** Tried and tested in the harshest weather conditions, a summary of our guarantee is listed below, see our website for full details:

- **Mechanical components: 100% guarantee for two years, followed by an eight year graduated guarantee.**

**RAIN INGRESS:** Please note that in extreme weather conditions some moisture will penetrate a mesh material.

**RIGHTHAND TO LEFTHAND SPRING CONVERSION**

RH = Drive bracket on the right with spring bracket on left

For LH to RH conversion, follow instructions in reverse order

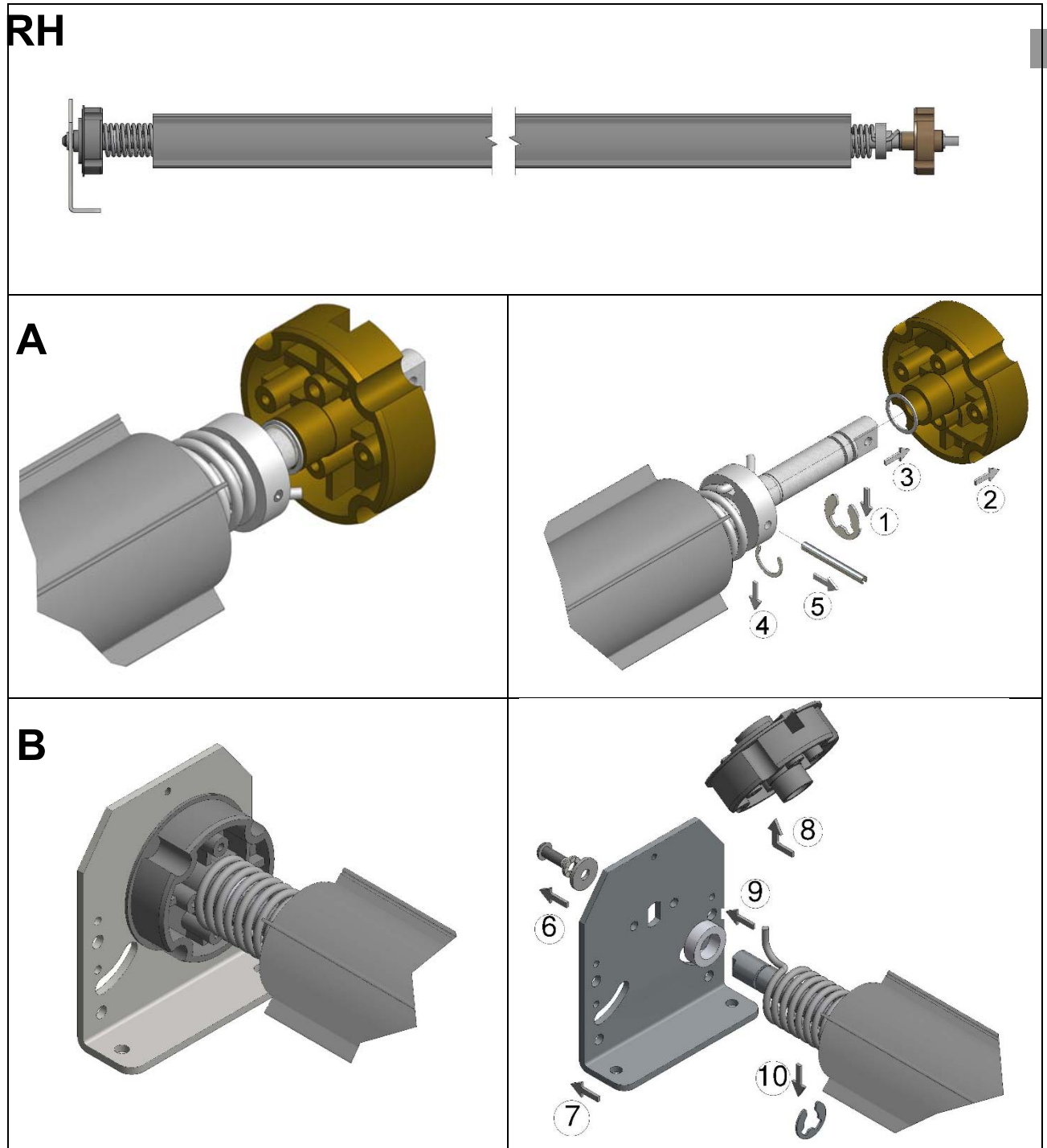

GB

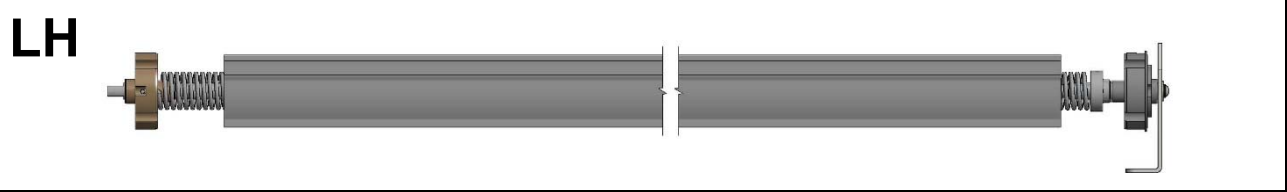
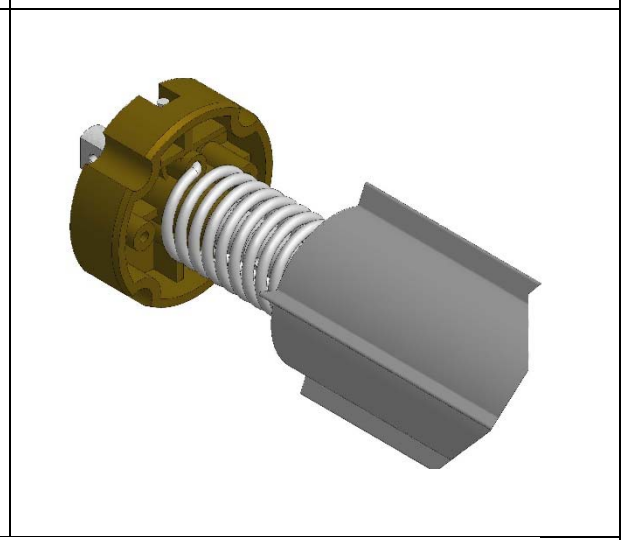
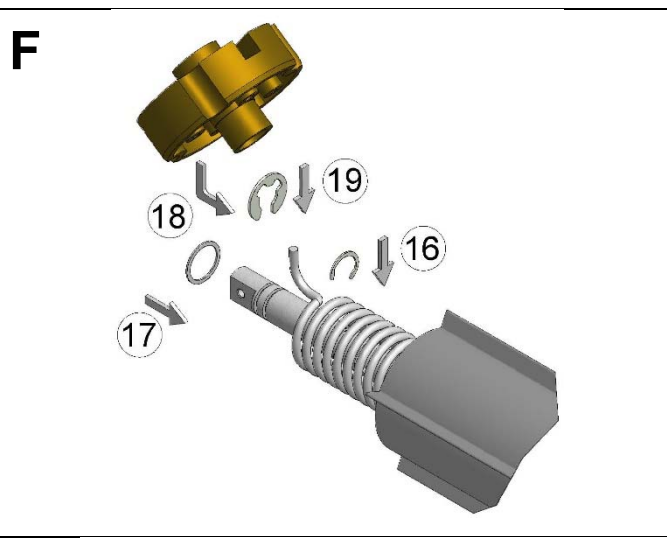
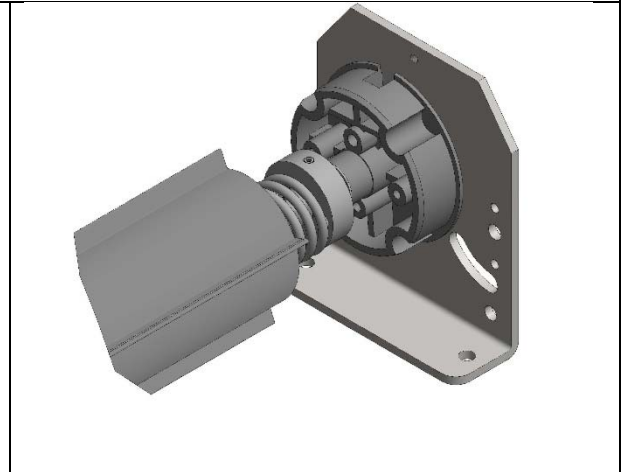
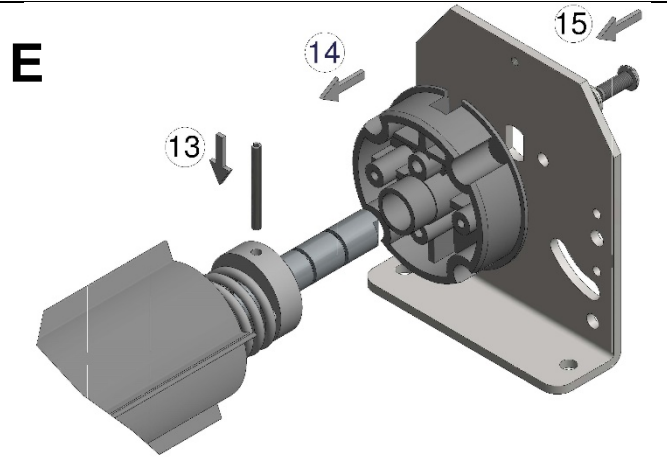
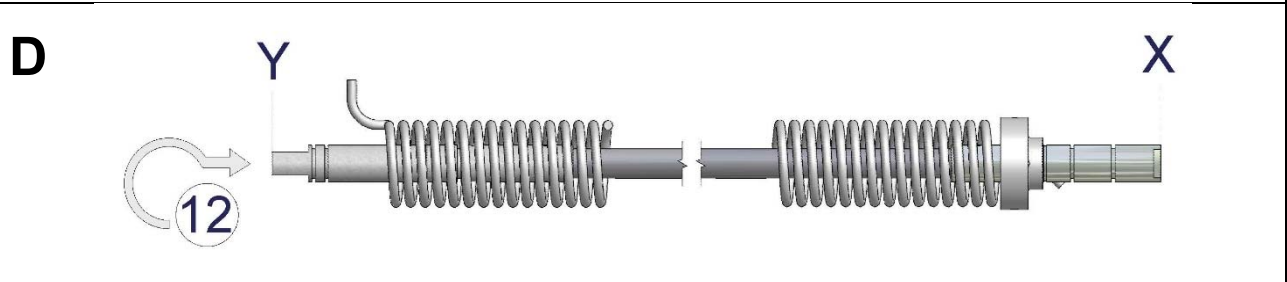
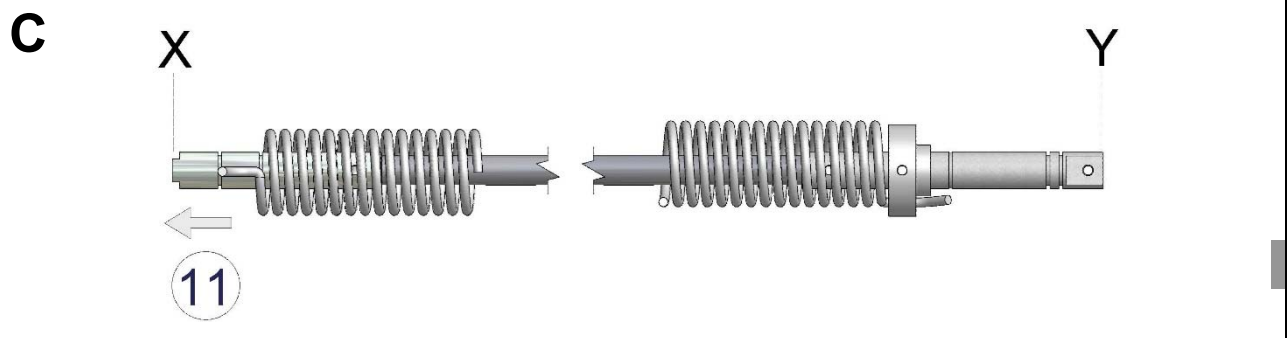

**RIGHTHAND TO LEFTHAND CHAIN TENSIONER CONVERSION**

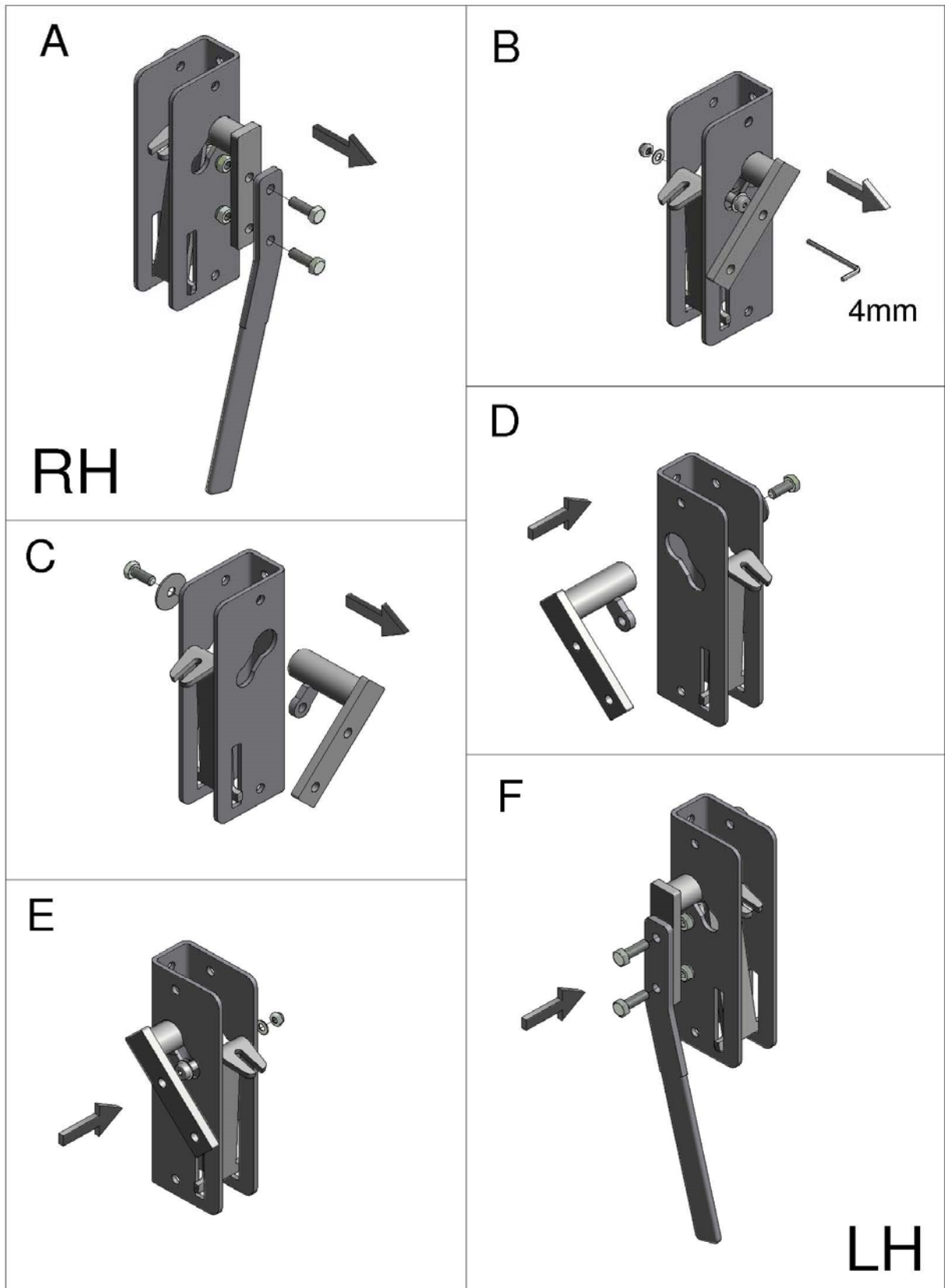



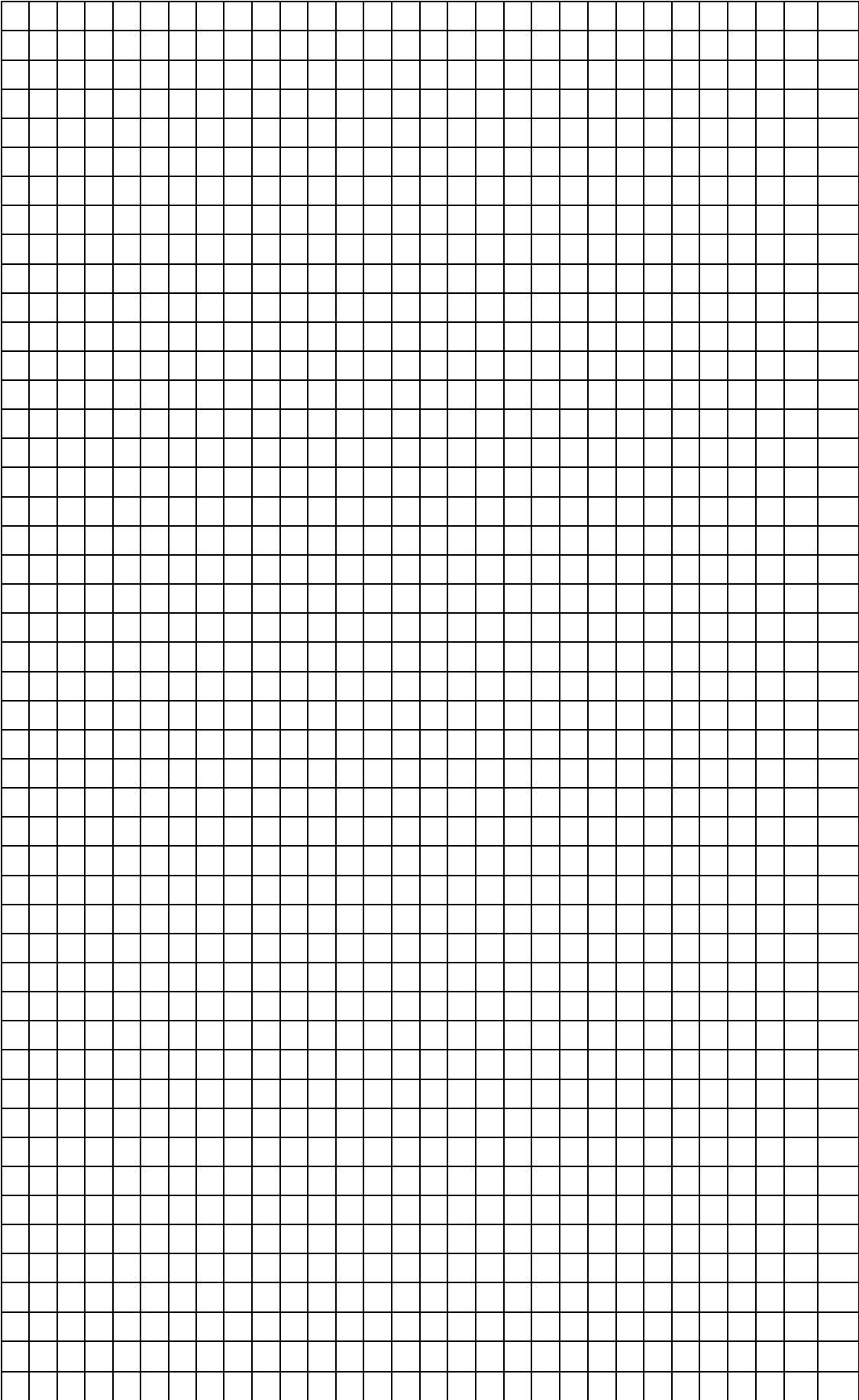

GB

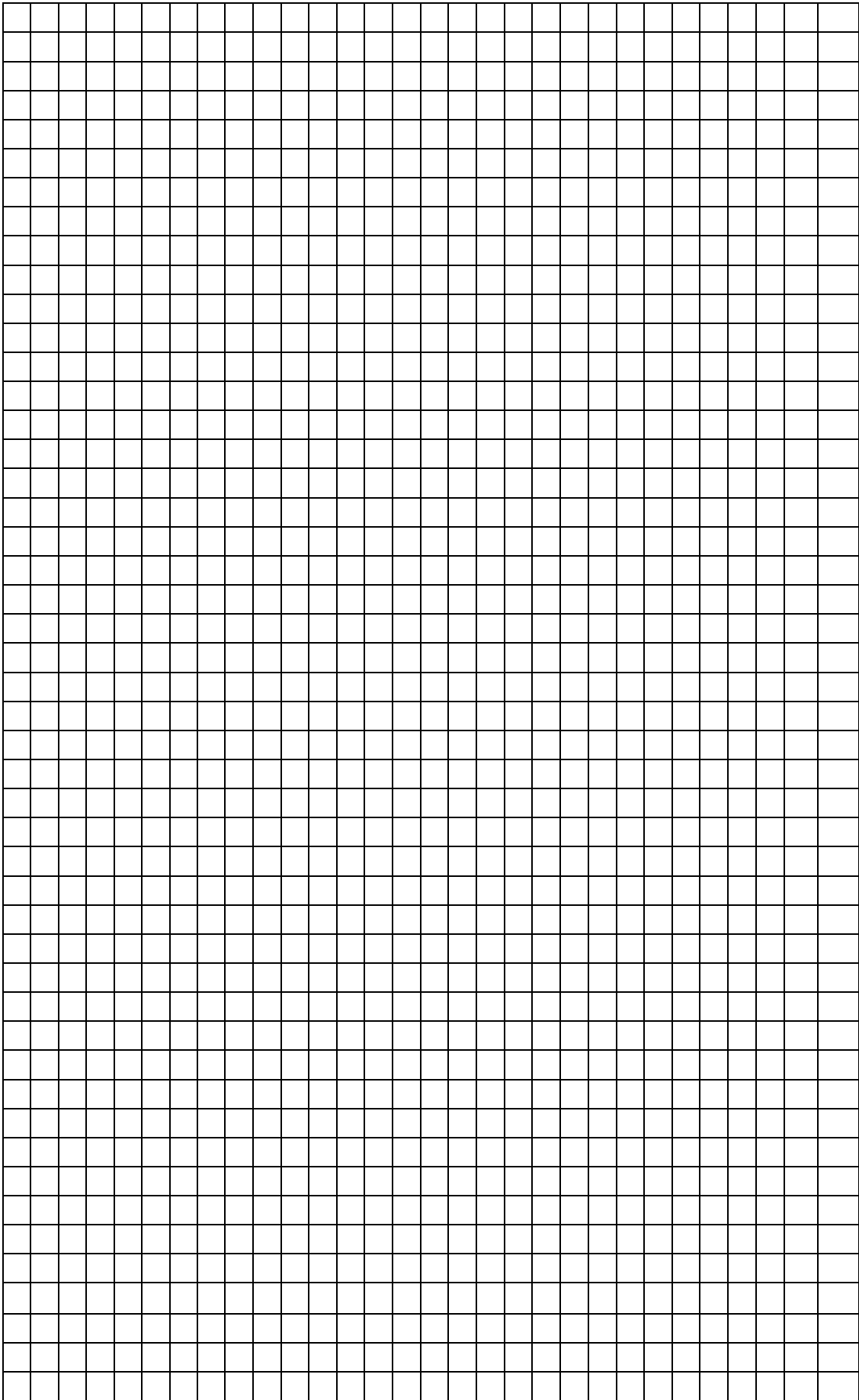

GB

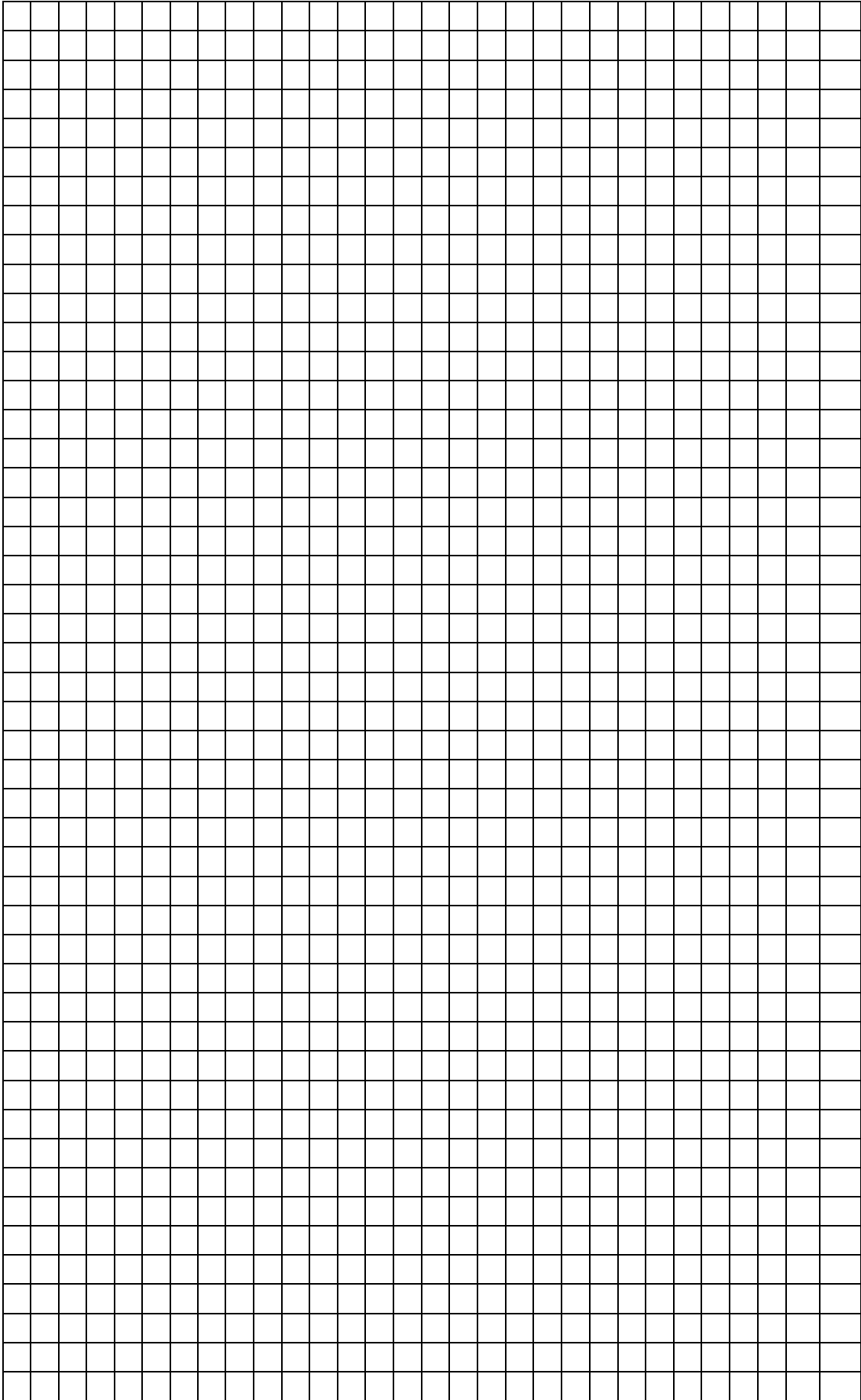

GB



**Manufacturer:** Galebreaker Agri Ltd  
Galebreaker House  
New Mills Industrial Estate  
Ledbury  
Herefordshire, UK  
HR8 2SS

**Tel:** +44 (0) 1531 637 900

**Fax:** +44 (0) 1531 637 901

[www.galebreaker.com](http://www.galebreaker.com)

Designed and Manufactured in the UK by Galebreaker Agri Ltd.,

Original Instructions

© Copyright Galebreaker Agri Ltd 2023. All Rights reserved

**Model No: AD-CPM/Mk1/23/04**

**Instruction Ver: 2023/04/GB**