

# Trackscreen

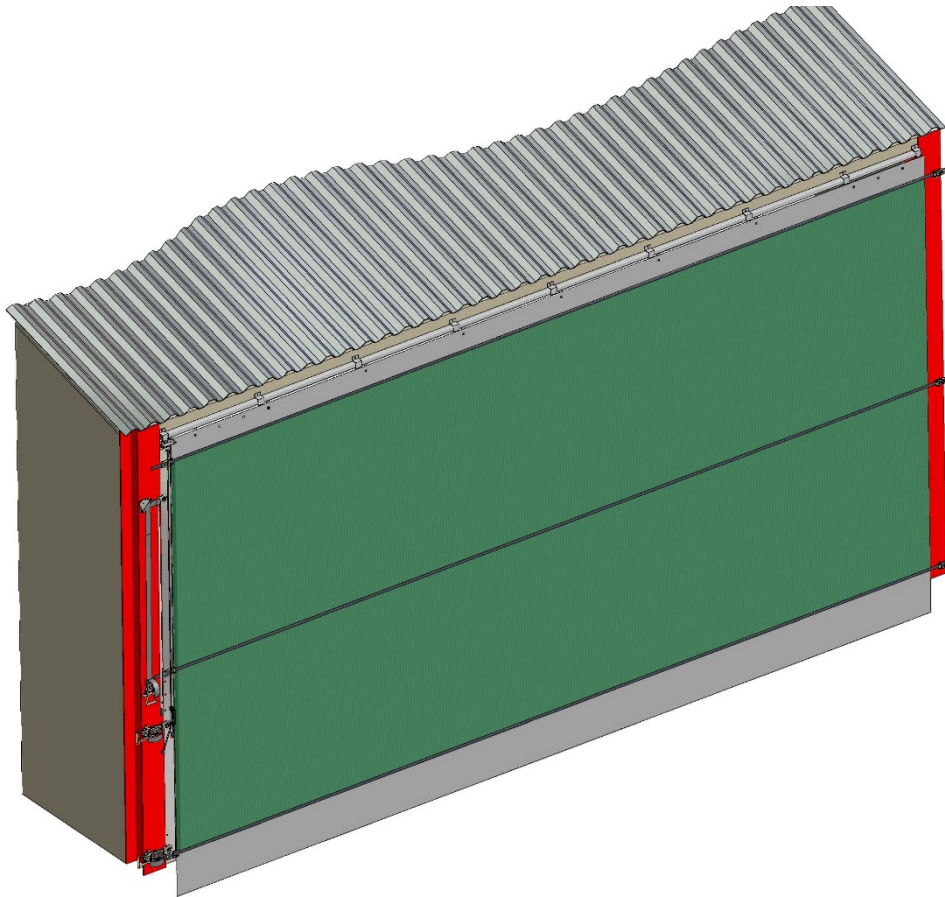

GB

## Installation and operating Instructions

***Galebreaker***<sup>®</sup>  
— AGRI —

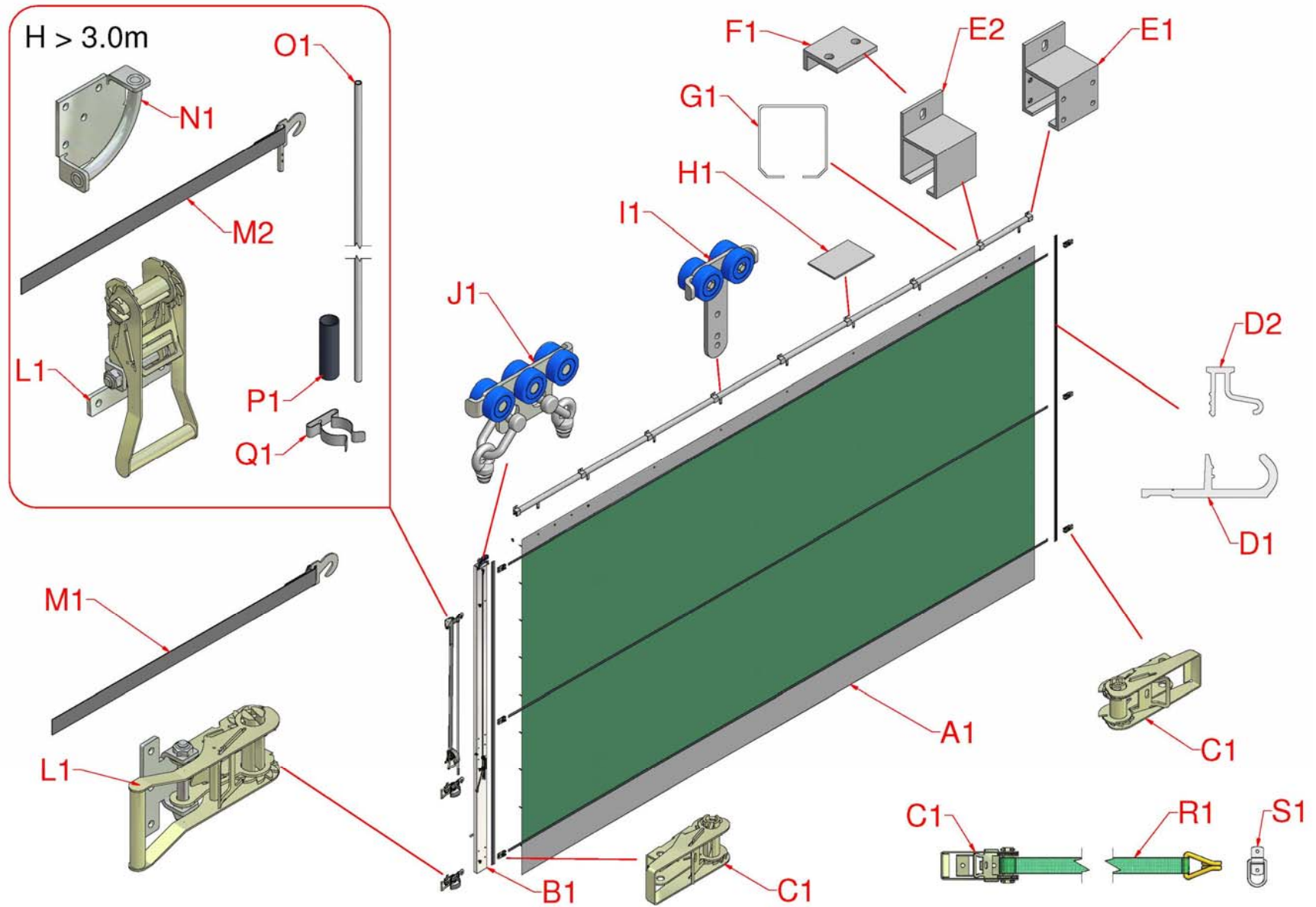

Figure1, System Overview and Individual Components

**INTRODUCTION*****Parts List***

Reference:	Quantity/Height			Product Description
	3.0m	4.0m	5.0m	
A1	1	1	1	Trackscreen
B1	1	1	1	Trackscreen Sliding Post Assembly
C1	6	6	8	25mm Ratchet
D1	6	8	10	Female Windseal (metres)
D2	6	8	10	Male Windseal (metres)
E1	2	2	2	Five Hole Track Support Bracket (end)
E2	*	*	*	One Hole Track Support Bracket (intermediate)
F1	*	*	*	Track Adaptor Bracket
G1	*	*	*	Steel Tracking
H1	*	*	*	Track Shim
I1	*	*	*	Four Wheel Trolley
J1	1	1	1	Six Wheel Trolley Assembly
K1	2	3	3	50mm Ratchet
L1	2	3	3	50mm Ratchet Fixing Bracket
M1	2	2	2	50mm Webbing and Hook
M2	-	1	1	50mm Webbing and Pinned Hook
N1	-	1	1	Webbing Corner Plate
O1	-	1	1	Extension Pole
P1	-	1	1	Black Handle Grip
Q1	-	1	1	Pole Retaining Clip
R1	1	1	1	Screen Tieback Strap
S1	2	2	2	Lashing Ring

GB

\* *The system length dictates the quantities not stated**L = Screen Length (m)*

**Fasteners and Quantities**

Screws for fixing the ratchets, windseal and extension pole are supplied.







<p><b>a</b> 50mm Ratchet 1 per</p>  <p>M12x90mm</p>	<p><b>b</b> Windseal - 2 per metre 25mm Ratchet - 2 per</p>  <p>M5.5x32mm</p>	<p><b>c</b> 5 Hole Track Bracket Qty = 4</p>  <p>M6x60mm</p>	<p><b>d</b> Track Adaptor Bracket Qty = 1 per</p>  <p>M8x20mm</p>
<p><b>e</b> Track Bracket - 1 per 50mm Ratchet - 3 per</p>  <p>M8x40mm</p>	<p><b>f</b> Sheet Support</p>  <p>M6x20mm, washers, spacer and nut</p>	<p><b>g</b> H &gt; 3m Extension Handle Qty = 2</p>  <p>M6x25mm</p>	
<p><b>h</b> Qty = 1</p>  <p>M10x30mm</p>			

Figure 2, Fasteners

***Your Safety***

The installation of the screen is not recommended at excessive wind speeds as it could cause damage to the curtain or injury to the Installer.

***Pre-Installation Check***

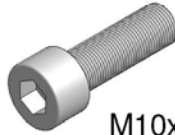
For structural requirements refer to attached Trackscreen Pre-Installations, these Installation Instructions assume all preliminary work has been completed.

***Right or Left Hand Opening***

Your Trackscreen will open towards the right. The images and text in these Instructions are also based on a Trackscreen opening to the right, if you require opening to the left then reverse the references.

***Items Required By The Installer***

Standard tool kit including:

- Sharp pair of scissors or knife
- Electric drill
- 18mm Masonry drill
- Boom or Scissor lift
- Bolts for fixing 50mm Ratchets and Track Brackets to a steel surface up to 25mm thick are supplied, alternative fixings are required for wood or concrete.
- Self drilling screws for fixing 25mm Ratchets and Female Windseal to a steel surface up to 12mm thick are supplied, alternative fixings are required for wood or concrete

**Key Instructions**

**CAUTION:** Potentially hazardous situation: must be avoided otherwise injuries may result.

GB



**ATTENTION:** Observe the given instructions otherwise the product or adjacent items may be damaged

**NOTE:** Helpful comments and information to assist in installation or use of your product

**NOTE:** Before starting the installation it is advisable to read these instructions completely to help understand the general procedure and options available. Keep the instructions supplied for reference purposes.

**NOTE:** Colour versions of the installation instructions can be downloaded from our website:

[www.galebreaker.com](http://www.galebreaker.com)

**INSTALLATION**

1. Bolt the six wheel trolley assembly (J1) onto the top of the sliding post, Figure 3.

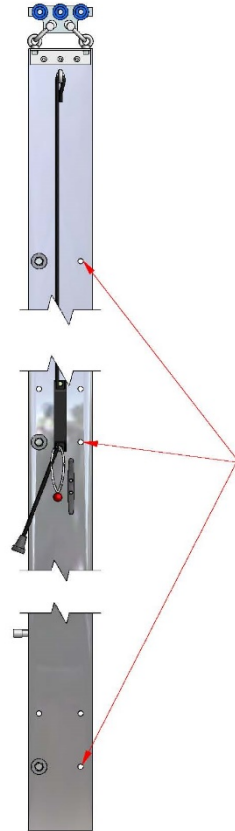
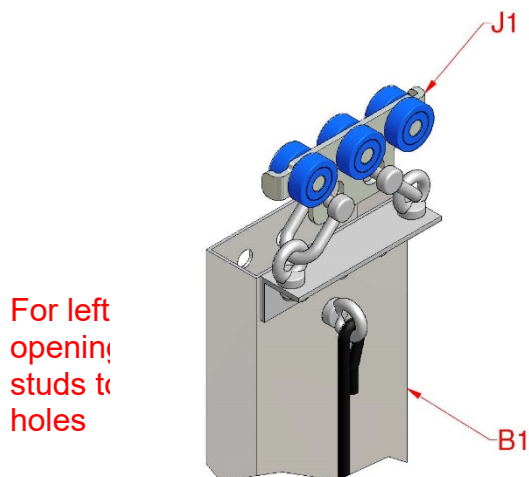

*Figure 3a,  
Post and  
Trolley*

2. The sliding post is delivered for a system opening to the right. The locating studs for the snap hooks are pre-fixed on the left-hand side of the post ready for the 'windseal' aluminium profile to be positioned to the other side. If your system is to open to the left, move the locating studs to the pre-drilled holes on the opposite side as in Figure 3a.

If you are installing a Double Trackscreen with Central Closing (see Pre-Installation Instructions Section 7.1), move the lower locating stud/studs on the left hand post to the pre-drilled holes directly above them, Figure 3b.

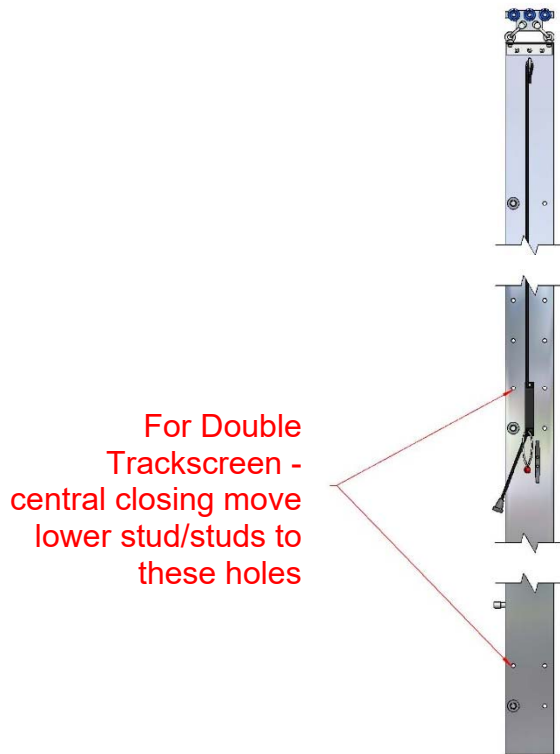

Figure 3b, Post for Double Trackscreen – Centre Closing

When using option C lintel fix (see Figure 5) it may be necessary to move the trolley mounting angle to the inside of the post so that the post aligns with the building upright when closed, Figure 3c.

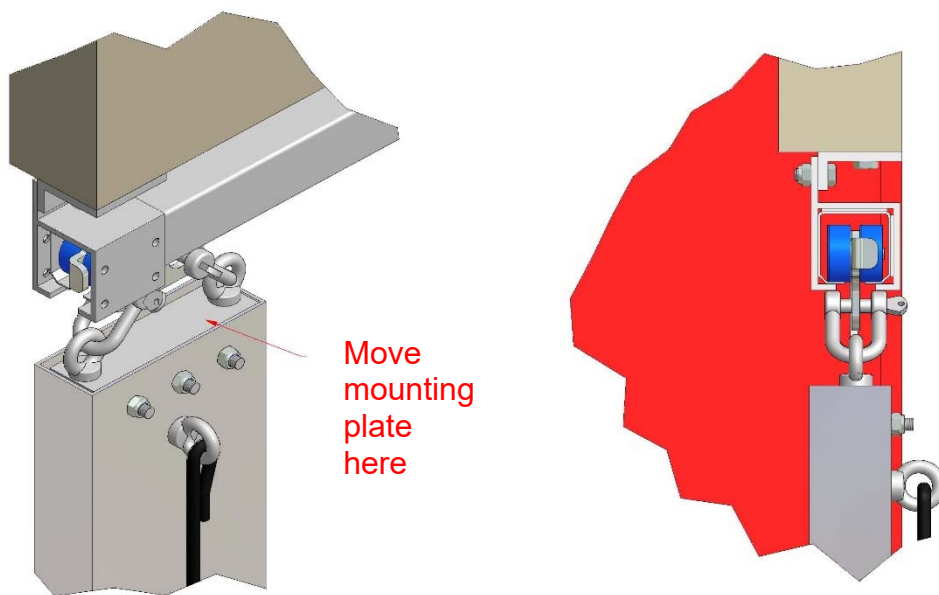

Figure 3c, Centre Trolley Alignment



3. Fix the female windseal profile (D1) to the full length of the sliding post with the M5.5x32 self-drilling screws (b) at 50cm centres and a maximum of 5cm from each end, a M10x30 cap screw (h) is supplied for fixing the self drillers.

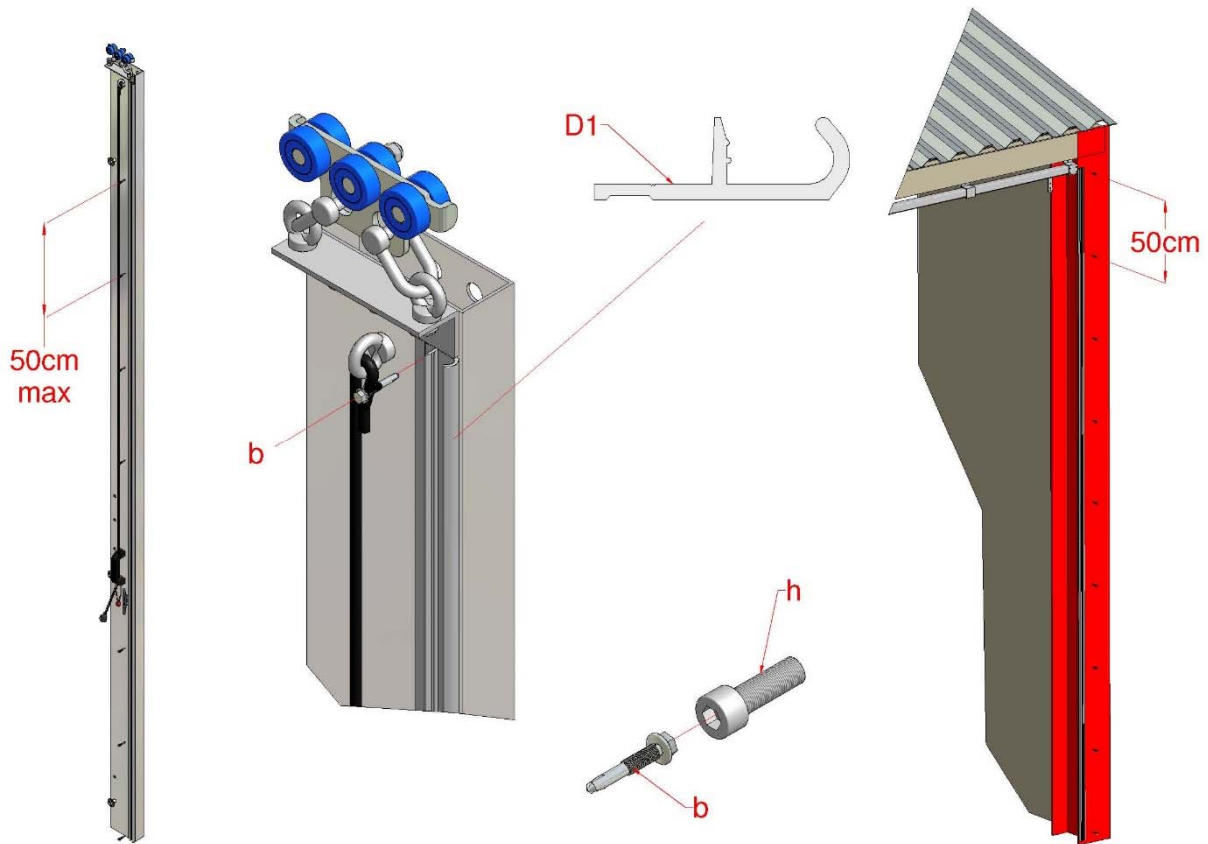

Figure 4, Fixing the Windseal

4. Fix the female windseal profile (D1) to the full height of the opening at the fixed (non-opening) side with the M5.5x32 self-drilling screws (b) at 50cm centres and a maximum of 5cm from each end.
5. Fasten the tracking onto the building with the M8x40 bolts supplied (e). The orientation of the track support brackets (E1, E2 and F1) for face or lintel fixing to be the same as that decided when the order was placed, Figure 5. Support brackets to be positioned at 1.0m centres. Insert the tracking with the track shims (H1) on the joints. Leave the fixed (non-opening) end section of track out at this stage. To help in the smooth running of the trolleys file the ends of the tracking. Seal off the ends of the track by fixing the five hole track support brackets (E1) with the M6x60 screws and nuts (e).



**CAUTION:** Ensure the brackets are securely fastened to the building; failure of these fixings will result in potential injury to bystanders.

Face Fixing

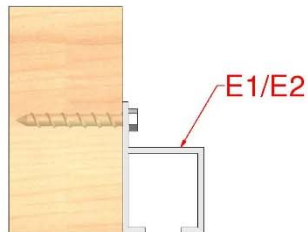

Lintel Fixing

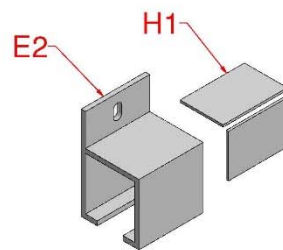
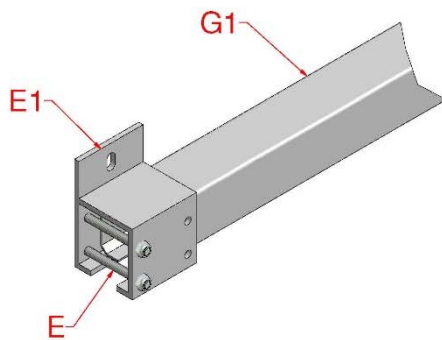
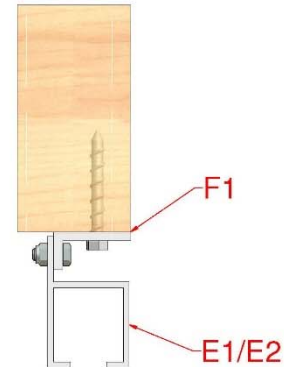
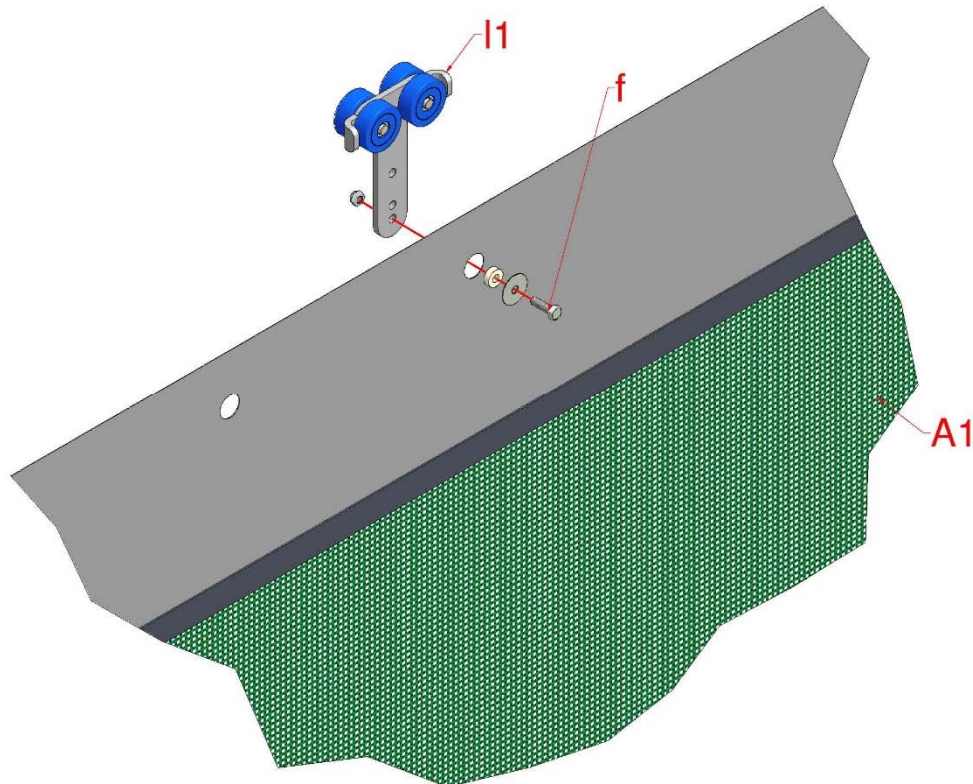

Figure 5, Track Fixing

- Attach the four wheel trolleys (I1) to the screen by bolting the eyelet onto the bottom hole of the trolley using the M6x20 setscrew, 15mm diameter spacer and large washers (f), Figure 6.

**NOTE:** At this stage only fix trolleys to the intermediate eyelets positioned at 100cm centres, i.e. leave the end three eyelets free.



GB

*Figure 6, Fitting the Trolleys*

7. Insert the sliding post assembly (B1) followed by a loose trolley into the track. Hang the screen by lifting it up to the track and inserting the trolleys one at a time into the track. Insert a loose trolley at the end and fit the missing end section of track.
8. Assemble the 50mm ratchets (K1) and ratchet brackets (L1) using the M12x90 bolt as shown in Figure 7 (i) or (ii) to suit mounting space available.
9. Fix two ratchet assemblies to the opening end of the building so that they align with the two locating studs of the sliding post, Figure 7.
10. **Only for screens over 3.0m in height.**
  - 10.1 Fix the webbing corner plate (N1) so that the identification notch aligns with the topmost locating stud. Fix a 50mm ratchet assembly directly below the bottom identification notch at a convenient operating height, Figure 7.

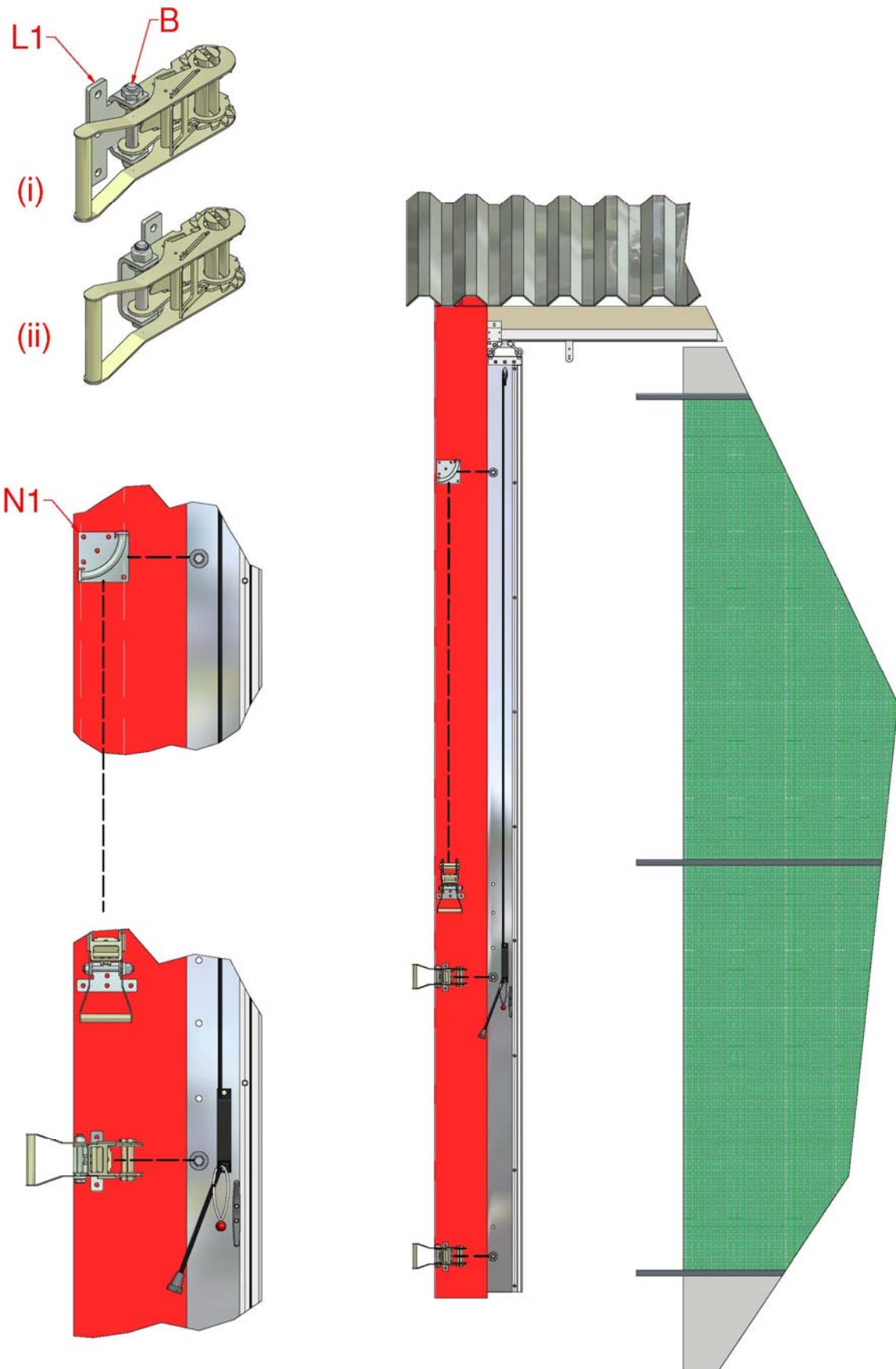

Figure 7, Securing the Sliding Post

- 10.2 Fix the aluminium extension handle (O1) to the pinned snap hook (M2) with the M6x25mm button screws (g) supplied. Ensure the nyloc nuts face outwards. Cut the extension pole to the appropriate length and push on the black handle grip (P1), Figure 8. Fit the pole retaining clip (Q1) to the building to hold the extension handle in place when not in use

GB

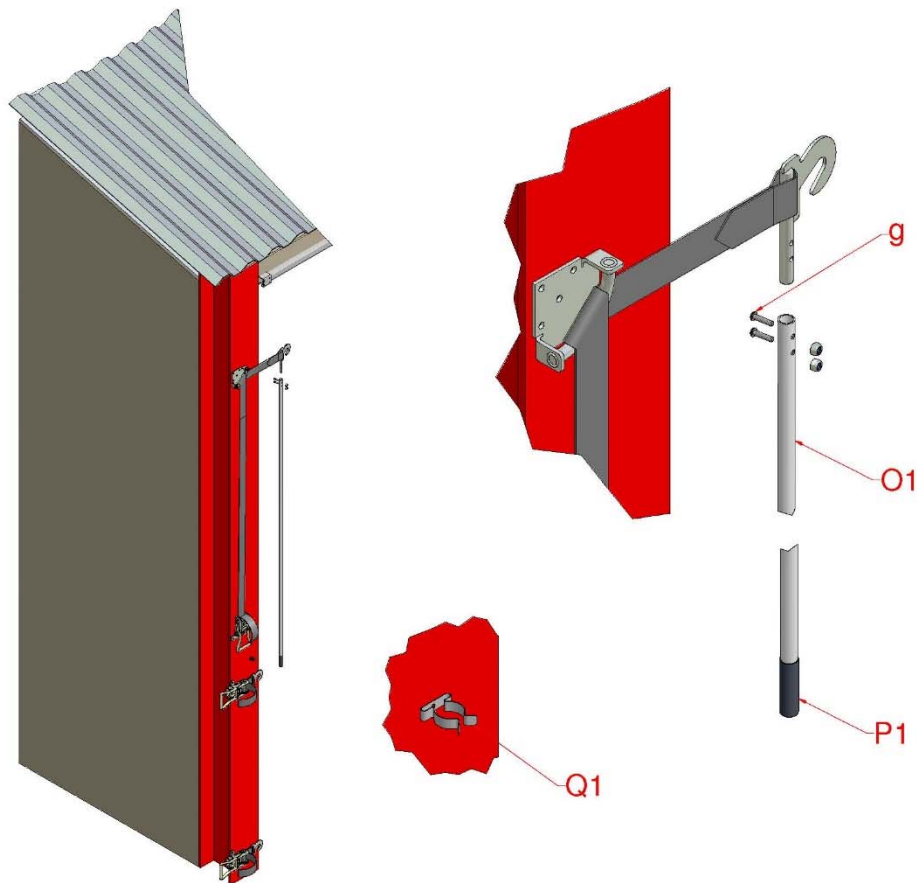

Figure 8, Extension Handle

11. Ensuring the screen is square (90°) to the line of the tracking, align the 25mm ratchets (C1) with the webbing straps on the screen and fasten them to the sliding post with the M5.5x32 self-drilling screws (b) supplied. Repeat the process at the fixed building end with your own fastenings for the ratchets, Figure 9.

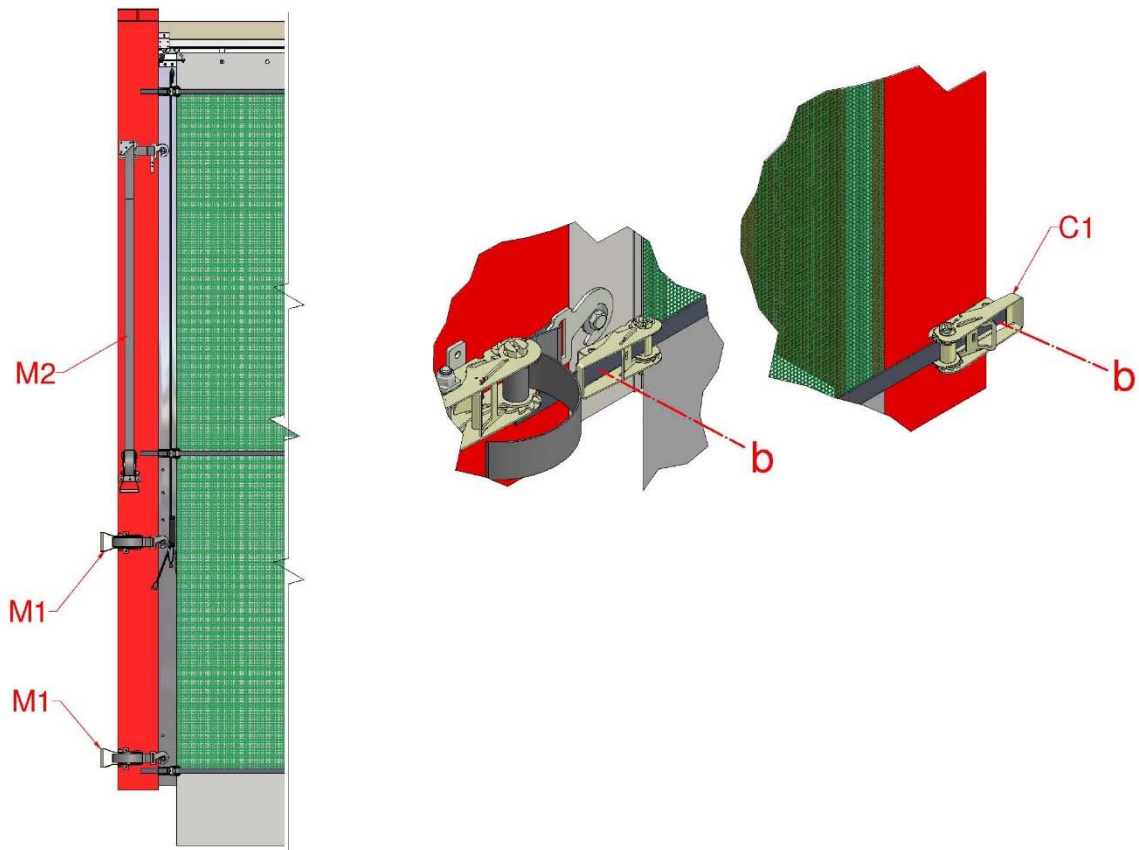



Figure 9, Fitting the Ratchets

12. Insert the 50mm webbing and hooks (M1/M2) into the ratchets. Pull the sliding post up to the building face; attach the hook to the locating studs and tension with the 50mm ratchets, Figure 9.
13. Insert the webbing straps into the 25mm ratchets at both ends of the screen and tension **fully**. The webbing strap is designed to pass over the top of the female windseal profile.



**ATTENTION: Tension ratchets fully, lack of tension will cause damage to the Trackscreen. Tension only by hand, use of levers could cause damage to the ratchets.**

 **ATTENTION:** To ensure the ratchet functions correctly there must be a minimum of 150mm webbing (for 50mm ratchet) or 100mm webbing (25mm ratchet) around the ratchet barrel for secure & permanent tensioning of the screen.

 **ATTENTION:** Overloading the ratchet barrel with webbing will restrict the tension you can apply to the screen due to an increase in friction and a decrease in leverage. To free surplus webbing pull ratchet release catch on handle and open 180 degrees until ratchet body is flat and pull on webbing strap.

14. Cut the male windseal profile (D2) to length to fit between the webbing straps. Fasten the screen into the female windseal profile on both ends of the screen by inserting the male piece. Fixing the male windseal part is easier if hammered in with a rubber or wooden mallet. It may be necessary to trim the screen either side of the webbing strap to allow the male piece to be inserted, Figure 10.

**NOTE:** Do not use a metal hammer as you will damage the windseal and screen material

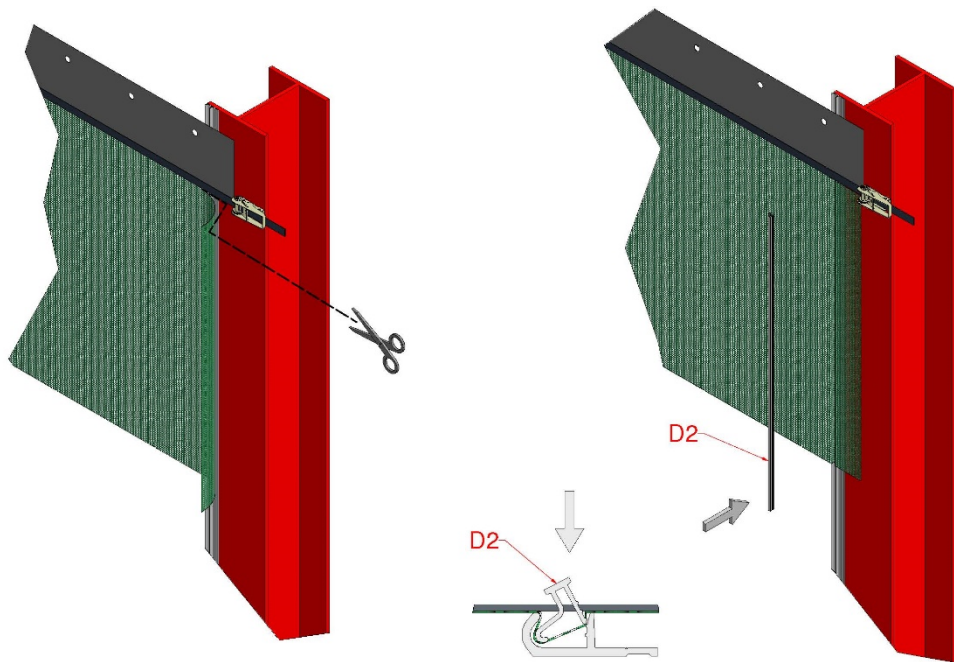
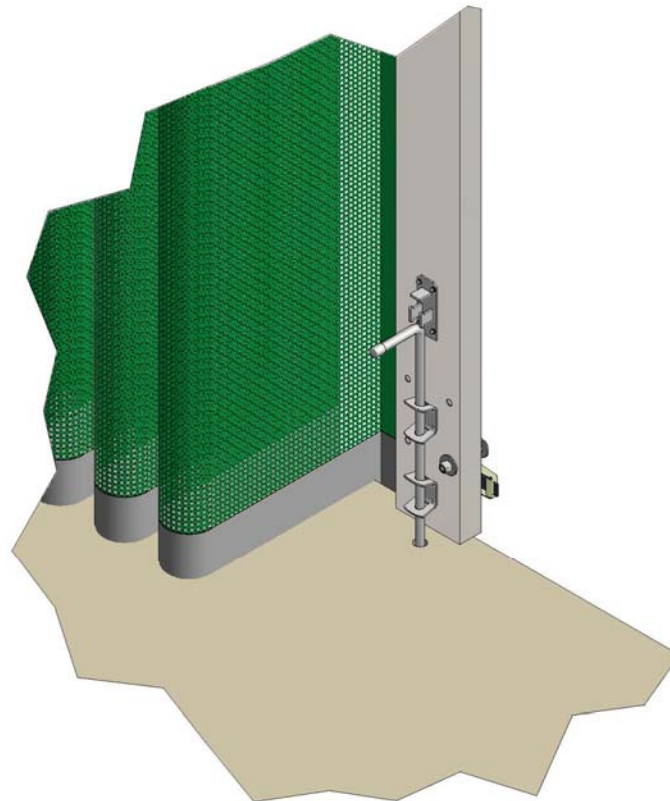

Figure 10, Fitting the Windseal

15. Trim the surplus material from the windseal profile leaving a 5cm flap. This flap will be useful should the screen have to be removed. Fix the outermost eyelet to the loose trolley each end using the relevant fixings as detailed in Section 6.
16. To fasten screen when open, drill a 18mm hole in floor to accept the sliding post surface bolt, Figure 11.

GB



*Figure 11, Surface Bolt*

17. Fasten the lashing ring (S1) to the building upright as shown in Figure 11. Fasten the 25mm ratchet (C1) to the inside of the building at the same height as the lashing ring. Attach the hook of the 25mm screen tieback strap (R1) to the lashing ring, around the folded trackscreen and onto the ratchet. Tension the ratchet to secure the Trackscreen. It is important that the screen is pulled together as tight as possible when open to prevent screen damage during gusts of wind. Fasten the second lashing ring to the building above the internal ratchet to hang the tieback strap to when not in use, Figure 12.



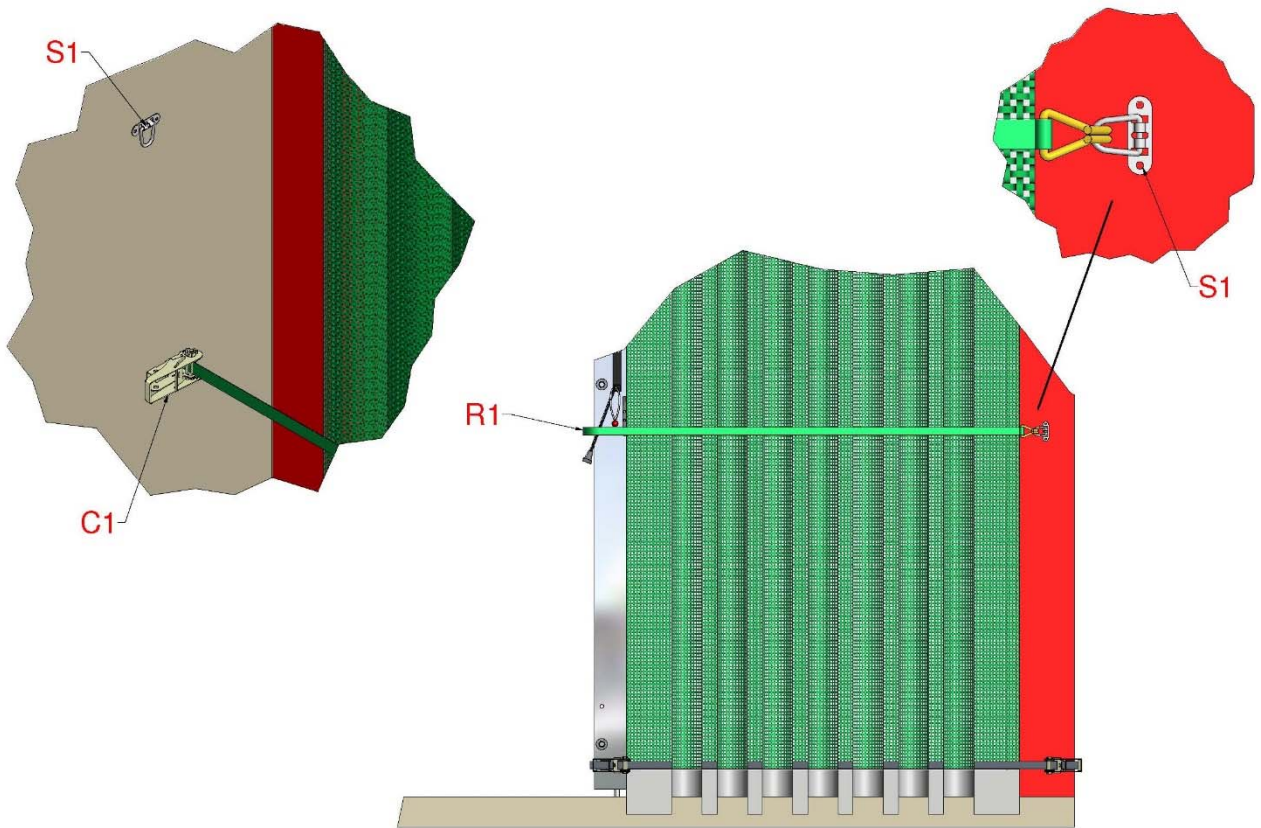

Figure 12, Trackscreen Tieback

**YOUR TRACKSCREEN IS NOW READY TO USE.**

## How to use your Trackscreen

From the open position, release the screen tieback strap and withdraw the surface bolt. Holding the rope pull and/or hand grip attached to the sliding post pull the screen across the opening with steady action. Clip the webbing and hook (M1) onto the posts' locating studs and tension the screen with the 50mm ratchets (K1) until the sliding post is adjacent to the building and the screen is taught.

GB

For trackscreens supplied with a third hook, once the above is complete, clip the top hook assembly (M2) onto the locating stud and tension the 50mm ratchet.

To open the trackscreen reverse the above procedure, again using a steady action.



**ATTENTION:** It is essential that the screen is pulled together tightly when open to prevent screen damage during gusts of wind.



**CAUTION:** During gusts of wind to prevent injury to operators/bystanders and damage to the screen, always leave your Trackscreen secured in the fully open or closed position.

---

## How to Maintain Your Trackscreen

When any steel work is showing signs of rust, coat with proprietary paint containing rust inhibitors. The sliding post and tracking are aluminium and do not require protection.

GB

Annually lubricate the ratchets to ensure their free operation.

Screen material, although the screen fabric has anti-tear properties, should it be damaged, the prompt application of a special repair kit (code SPS-99) available from your Galebreaker dealer, importer or head office will ensure the continued long life of the screen.

## How to Dismantle Your Trackscreen

Follow the installation instructions in reverse order.

**STORM:**

**This product has been designed and tested to British Standard BS EN 13241-1 with a Resistance to Wind Load rating of Class 4. Tried and tested in the harshest weather conditions, this product is fully guaranteed for two years, followed by a four year graduated guarantee.**

**RAIN INGRESS:**

**Please note that in extreme weather conditions some moisture will penetrate a mesh material.**



**Manufacturer:** Galebreaker Agri Ltd  
Galebreaker House  
New Mills Industrial Estate  
Ledbury  
Herefordshire, UK  
HR8 2SS

**Tel:** +44 (0) 1531 637 900

**Fax:** +44 (0) 1531 637 901



[www.galebreaker.com](http://www.galebreaker.com)

Designed and Manufactured in the UK by Galebreaker Agri Ltd.  
© Copyright Galebreaker Agri Ltd 2021. All Rights reserved.

**Model No: TS/MK3/05/2010**

**Instruction Ver: 2021/12/GB**