

# Rollerscreen

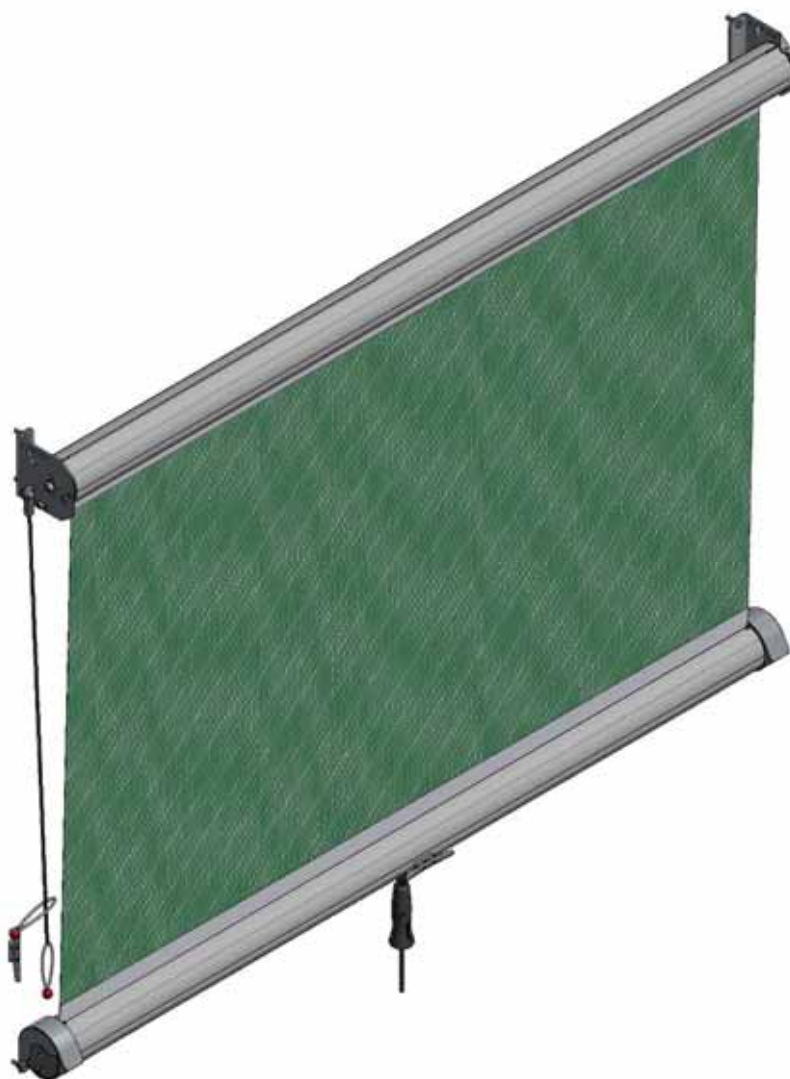

GB

## Installation and Operating Instructions

***Galebreaker***<sup>®</sup>

— AGRI —

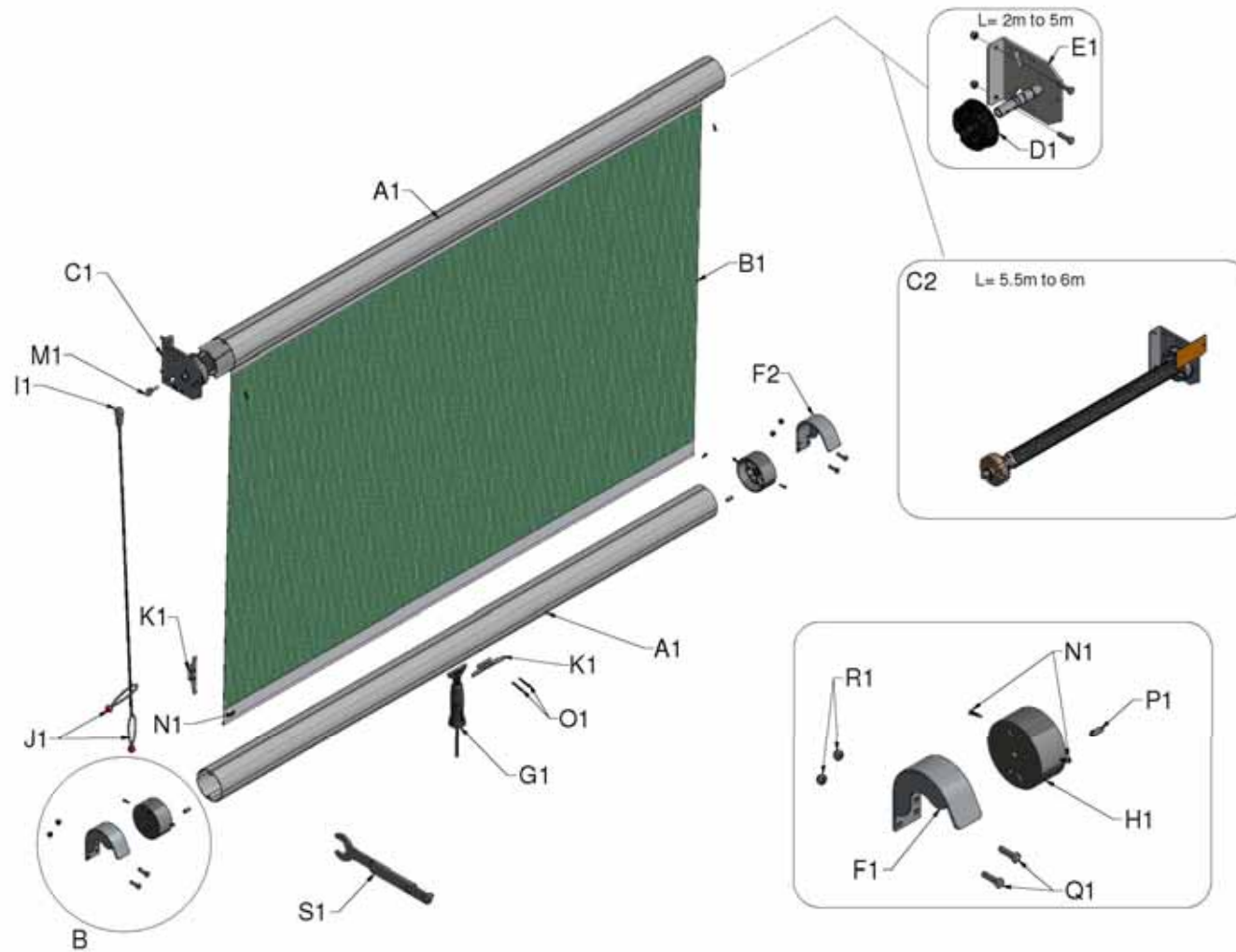

Figure 1, System Overview and Individual Components

**INTRODUCTION**

**Parts List**

REFERENCE	QTY	PRODUCT DESCRIPTION								
A1	2	Top and Bottom Tubes								
B1	1	Screen Material								
C1	1	Large Spring								
		Blind	2.5m	3.0m	3.5m	4.0m	4.5m	5.0m	5.5m	6.0m
		2.1m	2.32m long spring (Red tag)			2.97m long spring (Blue tag)				
		3.1m								
		4.1m								
C2	1	Doors over 5.5m in width: Small Safety Spring (Orange tag)								
D1	1	Doors up to 5.0m wide: Free end collar								
E1	1	Doors up to 5.0m wide: Free end bracket								
F1	1	Left hand 100mm Dia J Brackets BZP								
F2	1	Right hand 100mm Dia J Brackets BZP								
G1	1	Rope pull								
H1	2	End Caps								
I1	1	Rope and Hook assembly								
J1	2	Elasticated Loops								
K1	2	Cleats								
L1	1	Yellow Instruction sign (not shown)								
M1	1	Eyebolt & 2 nuts								
N1	8	M4 x 19 Self Drilling Screws for Fixing Screen End Caps								
O1	4	M4x38 Self Drilling Screws for Fixing Cleats								
P1	2	Insert Locker, Screw and Allen Key for Rope Pull Stop								
Q1	8	M8 x 30 Bolts for Fixing Brackets to Steel Building								
R1	8	M8 Nyloc Nut BZP								
S1	1	Spanner								
Y1	1	140x45mm Yellow Template (not shown)								

GB

**Your Safety**

The larger screens will require a mechanical lift to mount the roller assembly onto the top brackets. The respective weights are given in the table below based on standard material. Add 5% to this figure for doors supplied with ‘HP’ fabric, and 15% for doors supplied with black Stockscreen and solid fabrics.

WIDTH	HEIGHT		
	2.1m	3.1m	4.1m
2.5m	39kg	39kg	40kg
3.0m	43kg	43kg	44kg
3.5m	47kg	47kg	48kg
4.0m	51kg	51kg	59kg
4.5m	61kg	62kg	64kg
5.0m	65kg	67kg	68kg
5.5m	69kg	71kg	72kg
6.0m	74kg	75kg	76kg

**Pre-Installation Check**

Figure 2 indicates space required to install your screen with additional information for mounting multiple doors in series.

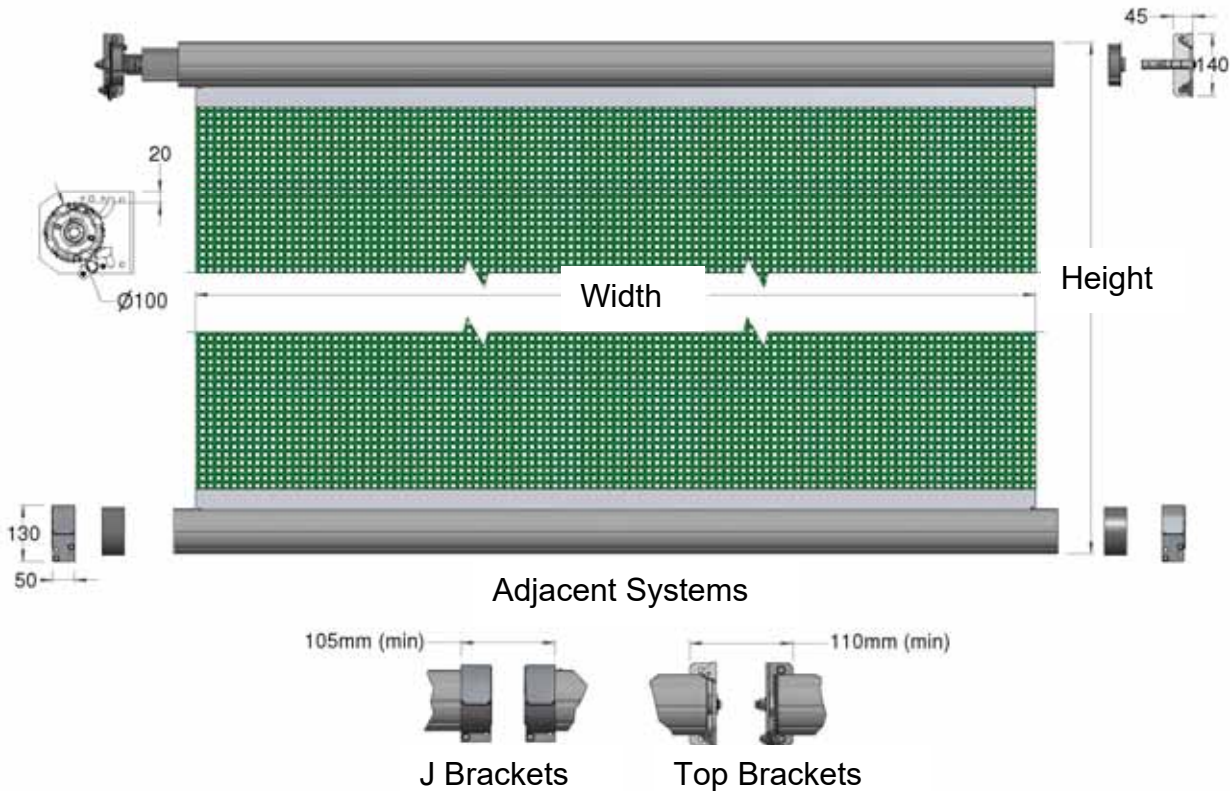

GB

Order Width (m)	Fabric Width (m)
2.5	2.5
3.0	3.0
3.5	3.5
4.0	4.0
4.5	4.5
5.0	5.0
5.5	5.5
6.0	6.0

Order Height (m)	Max Height (m)
2.1	2.10
3.1	3.10
4.1	4.05

Figure 2, Fitting Requirements

**Items Required By The Installer**

Standard tool kit comprising:

- Electric drill
- Angle grinder
- Sharp pair of scissors or knife
- Bolts for fixing the brackets to steel are supplied, if fixing to a wooden or concrete building you will require eight M8 fasteners.

**Key Instructions**

**CAUTION:** Potentially hazardous situation: must be avoided otherwise injuries may result.



**ATTENTION:** Observe the given instructions otherwise the product or adjacent items may be damaged

**NOTE:** Helpful comments and information to assist in installation or use of your product

For access to Installation Video  
scan QR code



**NOTE:** Before starting the installation it is advisable to read these instructions completely to help understand the general procedure and options available.

**NOTE:** Colour versions of the installation instructions can be downloaded from our website:

[www.galebreaker.com](http://www.galebreaker.com)

**INSTALLATION**

**Screen Assembly**

1. Check the contents of your screen against the parts list above. Do not let the screen material come into contact with any sharp objects or edges.
2. Using the yellow template (Y1), drill M8 holes for the two top brackets. The maximum recommended overlap for post fixing = 100mm and for lintel fixing = 175mm (Figure 3). It is essential that the top brackets are level and upright.

GB

**Post Fix**

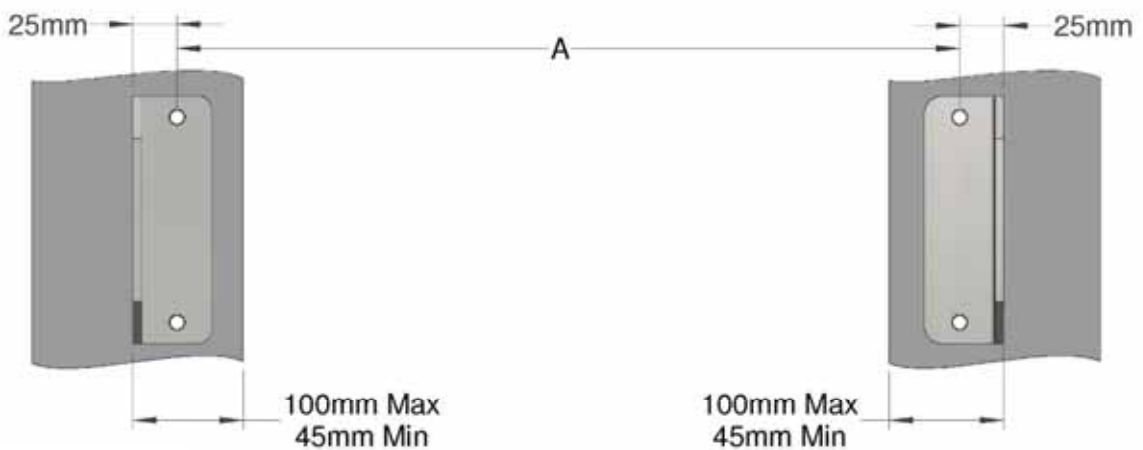

**Lintel Fix**

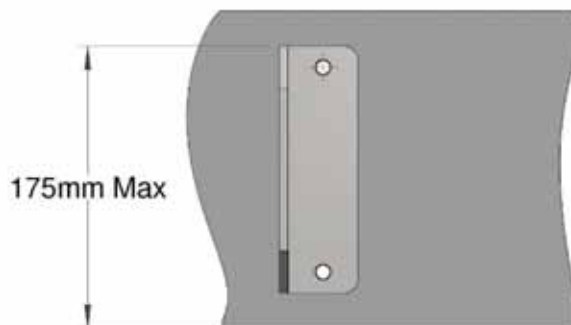



Figure 3, Top Bracket Positioning



**ATTENTION:** To prevent abrasion and material fray, maximum overlap between bracket face and edge of fixing must not exceed that shown in Figure 3. If overlap exceeds these recommendations ensure there are no sharp objects on the building to damage the material, and rough surfaces such as concrete is protected with PVC strip or similar.

3. Cutting lengths (Figure 4):

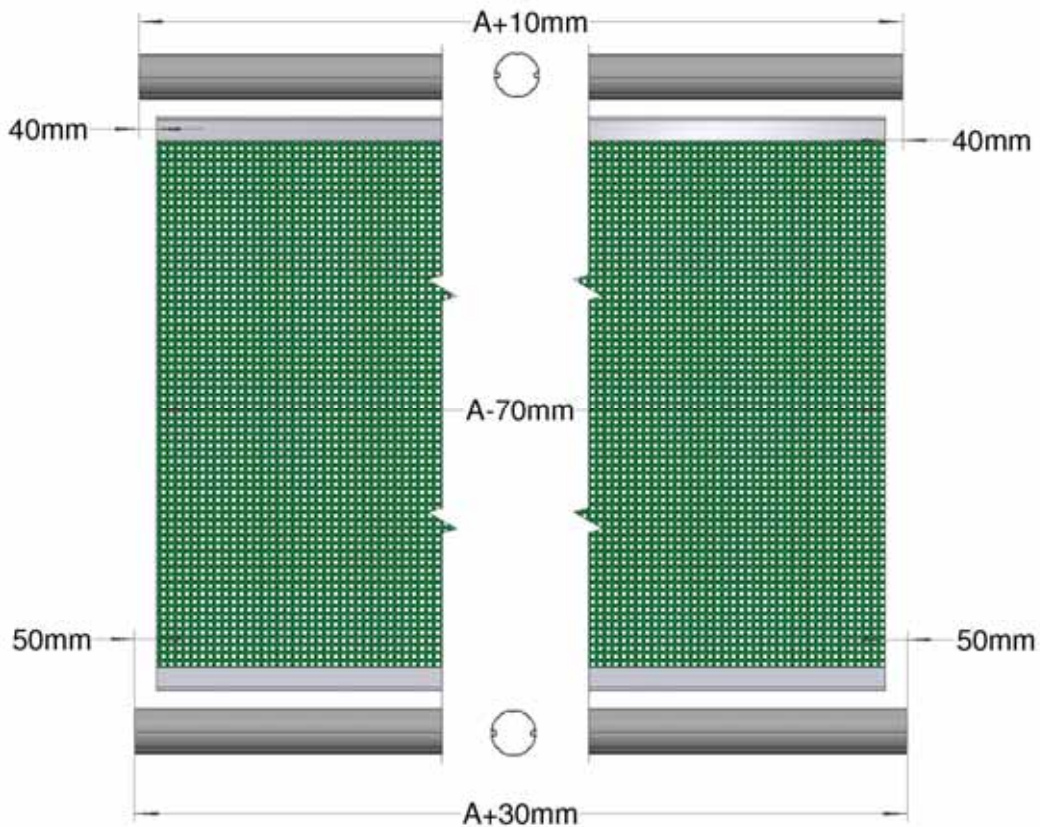
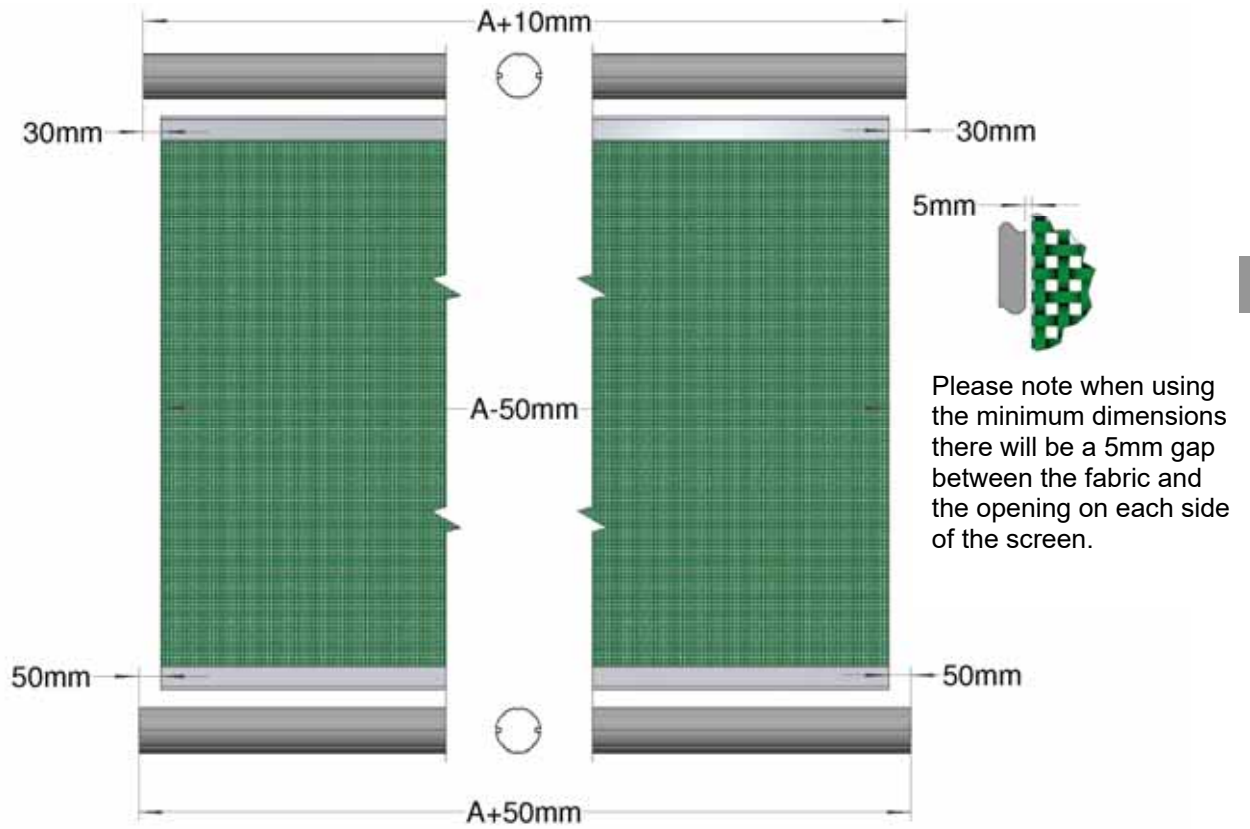

Figure 4a, Standard Cutting Lengths of Tubes and Fabric

- Top Tube = Distance between centre of drilled holes +10mm (+0.010m)
- Screen and Flap = Distance between centre of drilled holes -70mm (-0.070m)  
(80mm shorter than top tube)
- Bottom Tube = Distance between centre of drilled holes +30mm (0.030m)  
(20mm longer than top tube)

**NOTE: Cutting details are for standard installation where there are no constraints on fixing the top brackets or J brackets. It is possible to reduce the distance between top brackets if there are space constraints (Figure 4b). This configuration however results in a 5mm gap between the fabric and the door opening**





GB

Figure 4b, Minimum Cutting Lengths of Tubes and Fabric

4. Push the Flute Guide Insert over the end of the flute in the tube to protect the fabric sheet as it is being fitted. When the fabric is inserted remove the Flute Guide Insert from the end of the flute.





Slide the screen material (B1) into the flutes of the top and bottom tubes, Figure 5a.

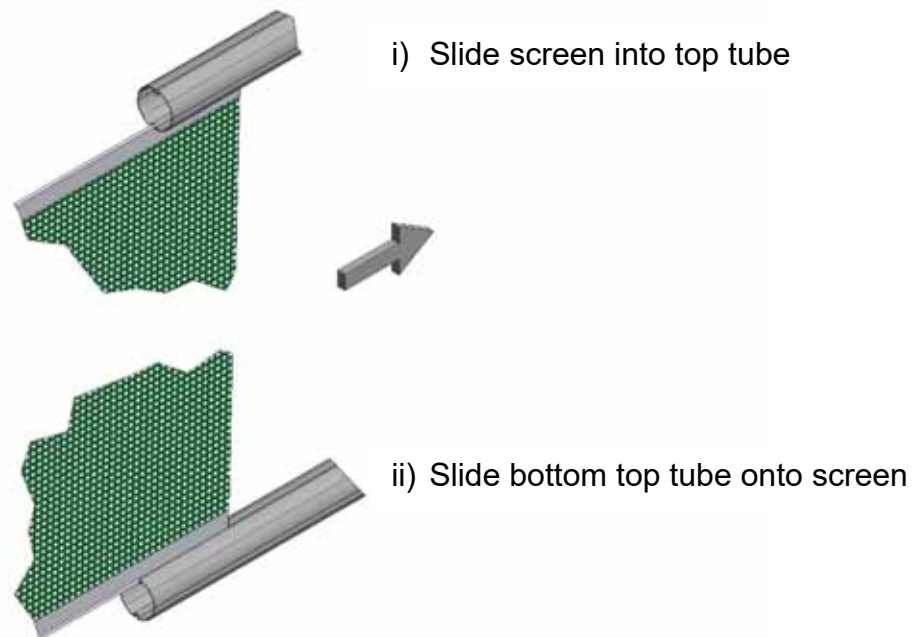

GB

*Figure 5a, Fabric Attached to Top and Bottom Tubes*

Slide the rope pull (G1) into lower flute of the bottom tube and position centrally along the tube. Assemble the M5 socket screw into the insert locker (P1) and position against the rope pull to create a stop. Push end caps (H1) onto bottom tube making sure the drainage holes are located vertically. Fix with 2 no. self-drilling screw to each cap (Figure 5b).

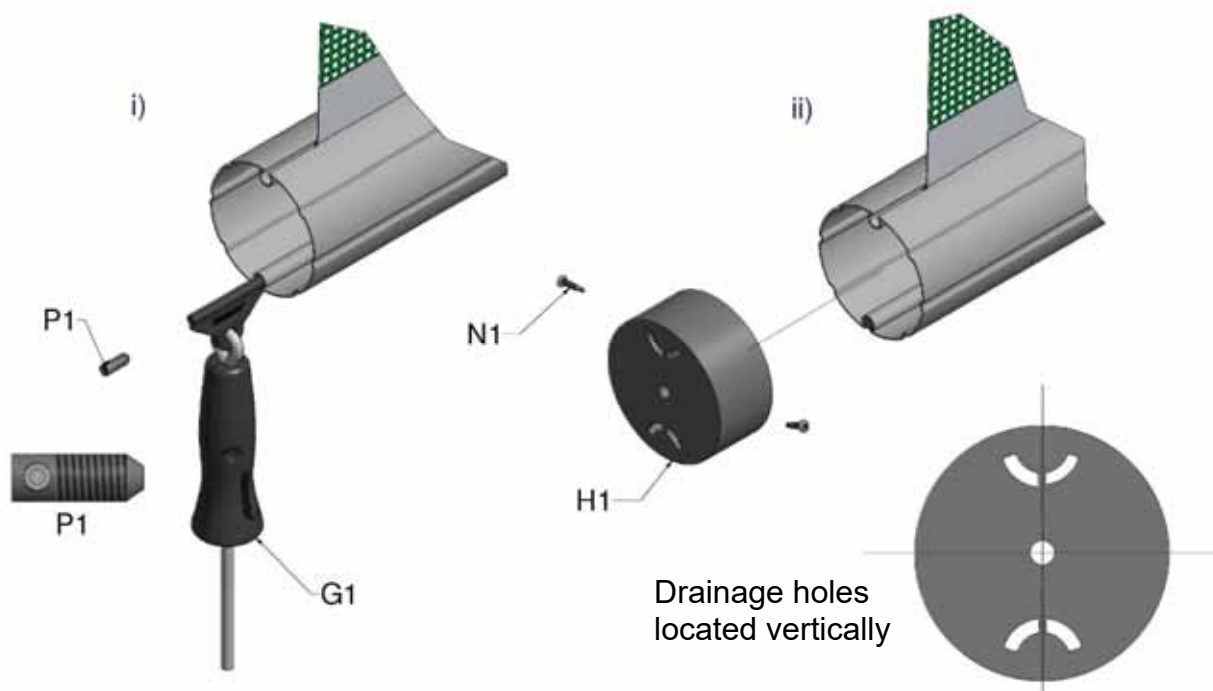

GB

Figure 5b, Attaching Rope Pull and End Caps

5. Roll the screen material fully onto the top tube by turning the tube in a clockwise direction when viewed from the large spring end (Figure 6i), and tie the tubes together. Connect eyebolt (M1) to the pawl on the spring locking mechanism; the eyebolt can face in or out (outside shown in Figure 6ii). Insert the large spring assembly (C1) into the left hand side of the top tube (Figure 6ii).

	<p><b>ATTENTION:</b> Check the material rolls off the back of the top tube and the spring is on the left. It is vital these instructions are followed correctly, <u>otherwise the spring will suffer terminal damage for which Galebreaker is not liable.</u></p>
--	---

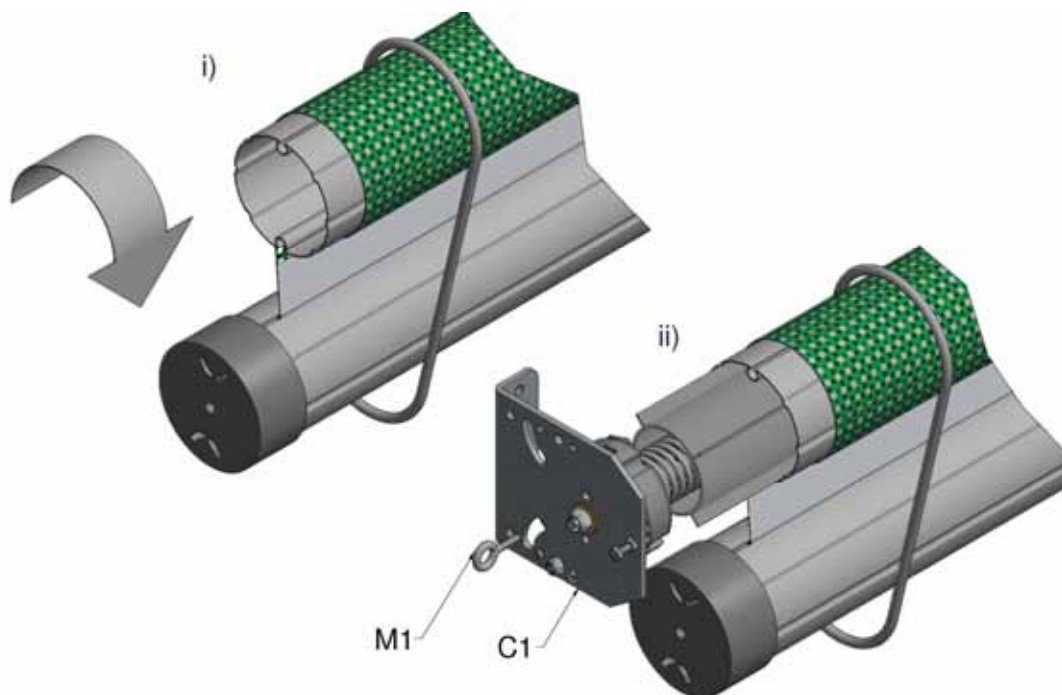

Figure 6, Roll Up Screen Around Top Tube and Secure

6.1. Screens up to 5.0m wide (Figure 7a):

Push free end collar (D1) into right hand end of the top tube and insert free-end bracket (E1). Lift the assembly into position, and bolt both brackets using the M8 fixings supplied.

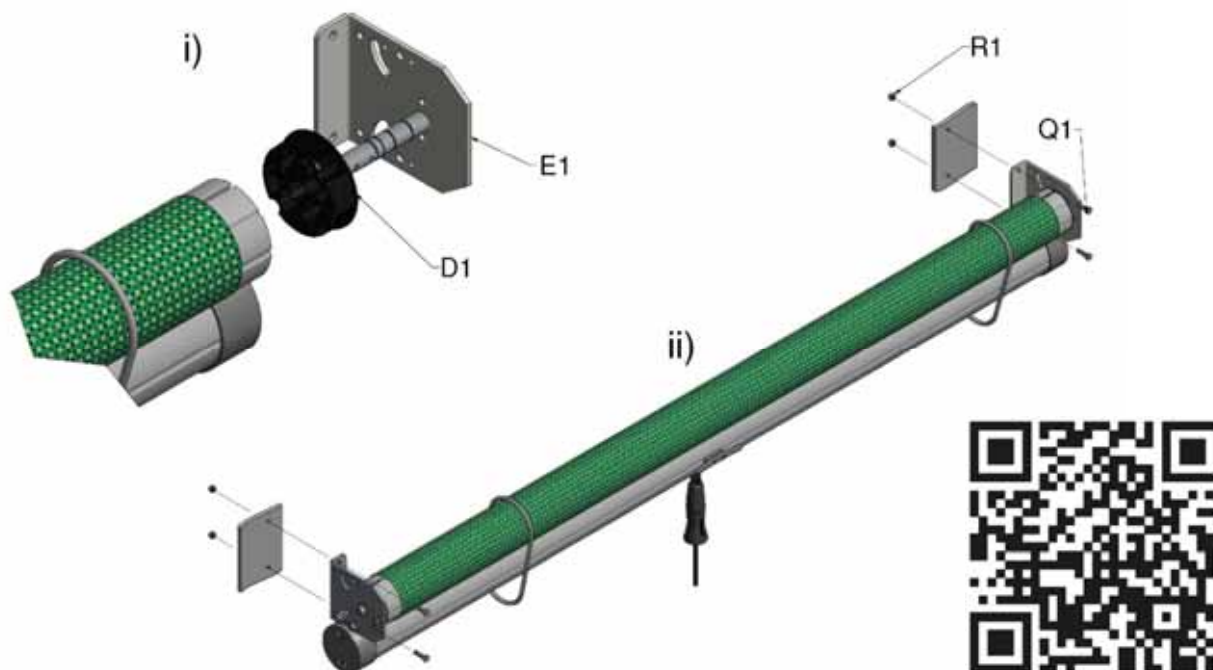
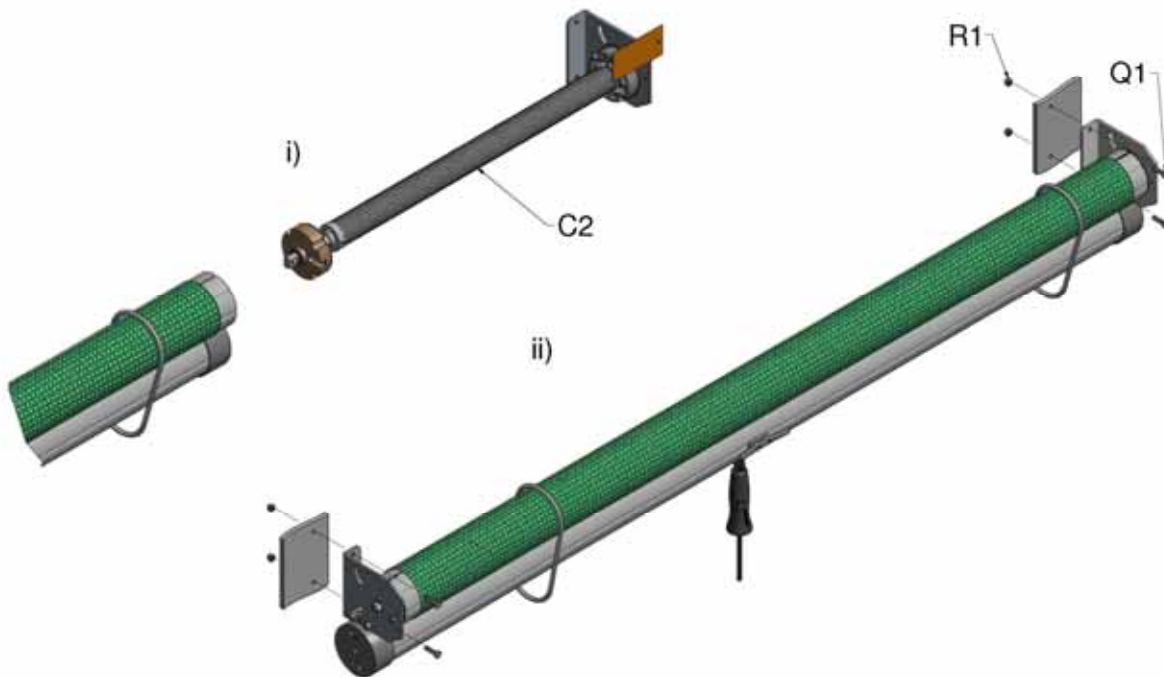

Figure 7a, Mounting Screens up to 5.0m Wide to the Building



6.2 Screens over 5.5m wide (Figure 7b):

Slide safety spring (C2) into right hand end of the top tube. Lift the assembly into position, and bolt both brackets using the M8 fixings supplied.



GB

Figure 7b, Mounting Screens over 5.5m Wide to Building

**CAUTION:** Only use M8 bolts or greater to fit the screen. Ensure all brackets are securely fastened to the building. Failure of these fixings will result in your screen falling off the building, potentially injuring operators and bystanders.

- Clip rope and hook assembly (I1) to eyebolt on locking mechanism. Fasten a cleat (K1) to building at the desired position together with the yellow instruction sign (L1). Tie both elasticated loops (J1) to rope (Figure 10), position each to secure the rope when the pawl is both open and closed.

**NOTE:** The locking mechanism prevents surplus material unrolling off the top tube, when the lower tube is secured in the J brackets; IT IS NOT DESIGNED TO LOCK THE SCREEN AT VARIOUS HEIGHTS.

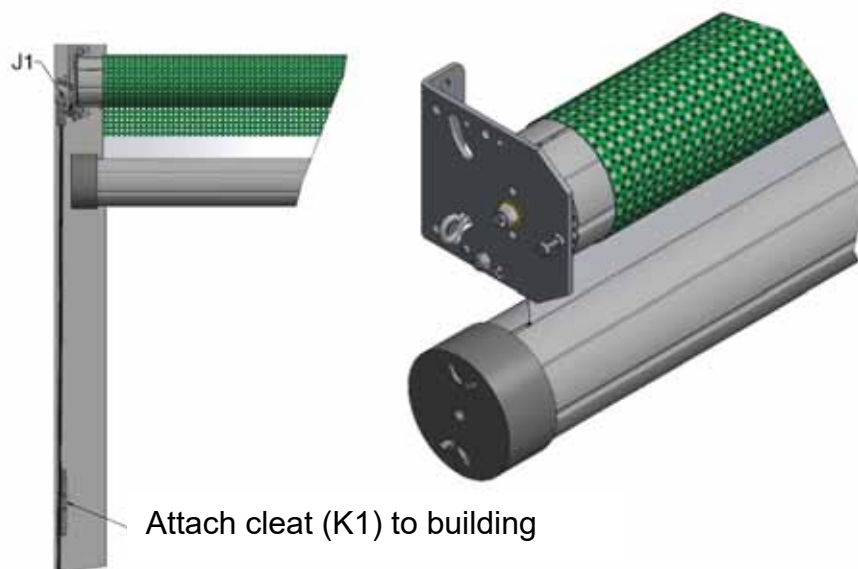

Figure 8, Cleat and Hook Placement

8. Assemble the spanner (S1) in the extended arrangement (Figure 9i) and engage on the hexagonal nut located between the cog and the top bracket, Figure 9ii. Rotate the spanner in the direction shown to wind the bottom tube up to the underside of the top brackets.

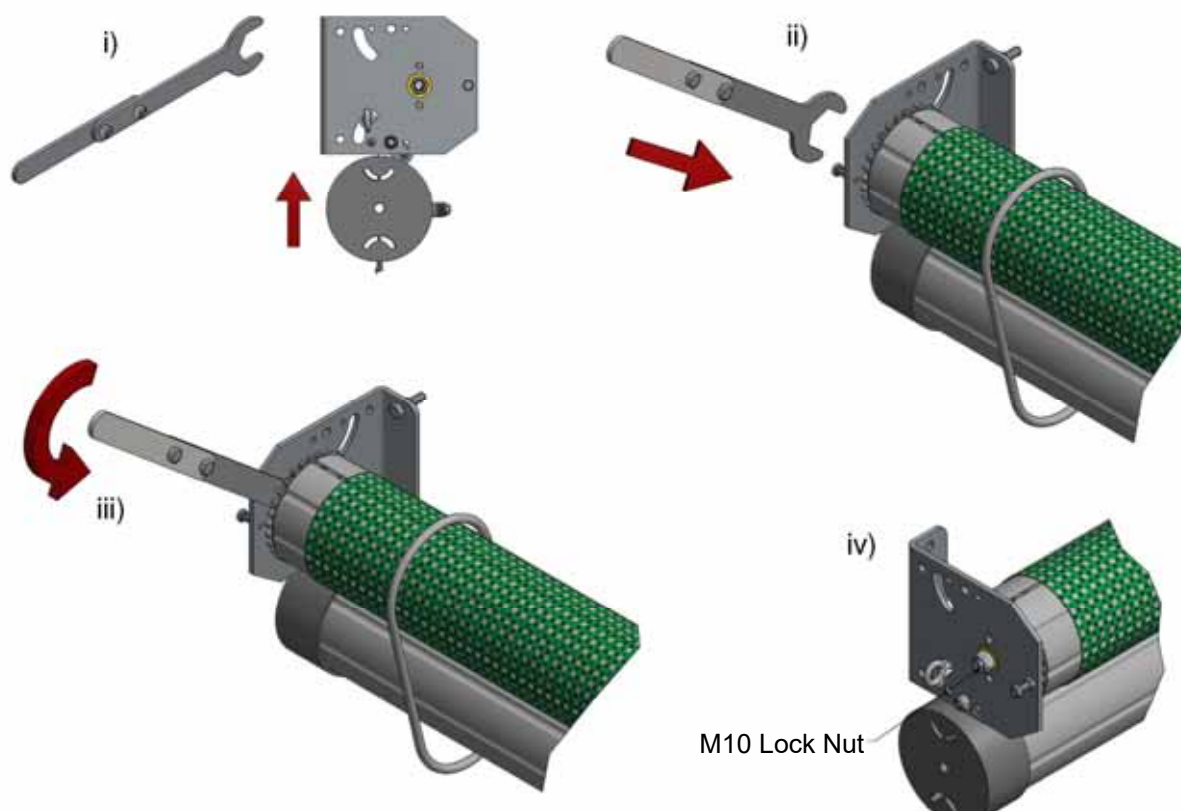

Figure 9, Tensioning the Spring



GB

As the spring is tensioned the mechanism will ‘click’ to prevent it unwinding. There are 6 clicks for a full turn. Tension the spring to the minimum requirement given in Table 1. (For Example 16 turns = 96 ‘clicks’)

Width	2.5		3.0		3.5		4.0		4.5		5.0		5.5		6.0	
Height	Min	Max	Min	Max	Min	Max	Min	Max	Min	Max	Min	Max	Min	Max	Min	Max
2.1	15	20	16	20	17.5	20	18.5	20	11.5	16	12	16	13	16	13.5	16
3.1	15	20	16	20	17.5	20	18.5	20	11.5	16	12	16	13	16	14	16
4.1	15	20	16	20	17.5	20	11	16	11.5	16	12.5	16	13	16	14	16

Table 1, Min – Max Spring Turns

When the spring is set to the required tension make sure the lock nut on the outside of the mounting bracket is tight.



**CAUTION: Make sure the M10 lock nut is tight.**  
**DO NOT OVER TIGHTEN the Nut**

- Fit one ‘J’ bracket (F1 or F2) at the desired level with the M8 fixings supplied. Ensure there is 120mm clearance underneath for the tube to engage into the



bracket. Locate tube under bracket and at other end, rest bracket over cap and press down until material is taut (Figure 10) and fix bracket to building.

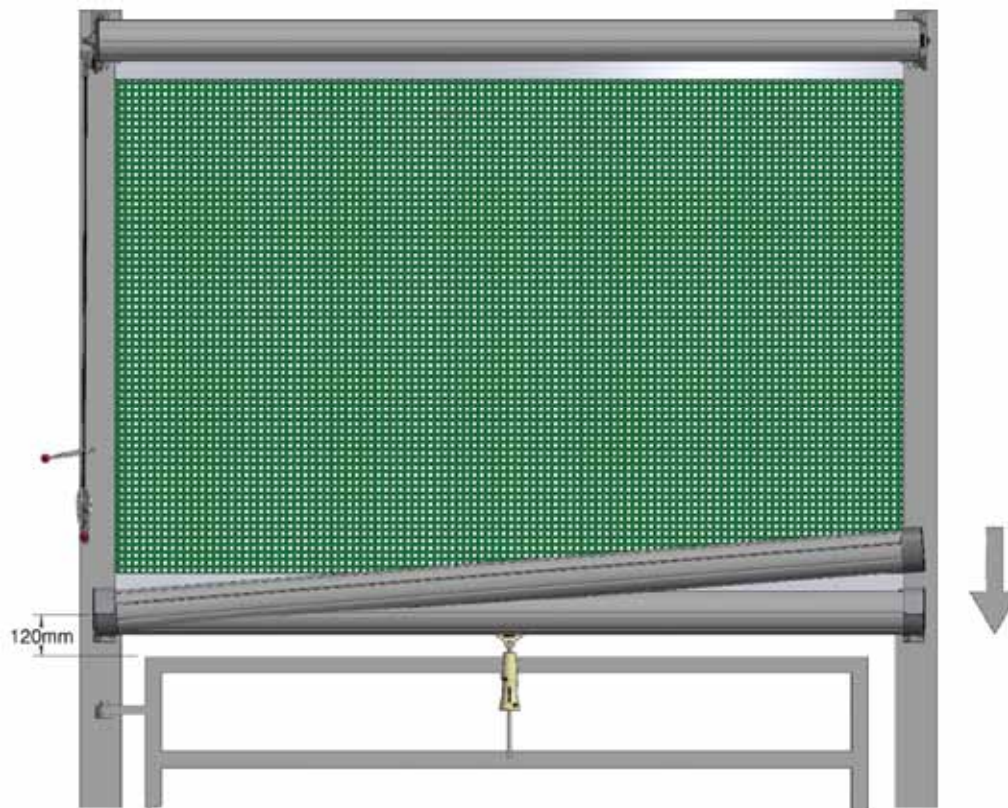

GB

Figure 10, Attaching 'J' Brackets to Building

**Securing Fabric**

10. Lower screen fully and re-engage the M6 bolt to lock the spring mechanism (Figure 11a).

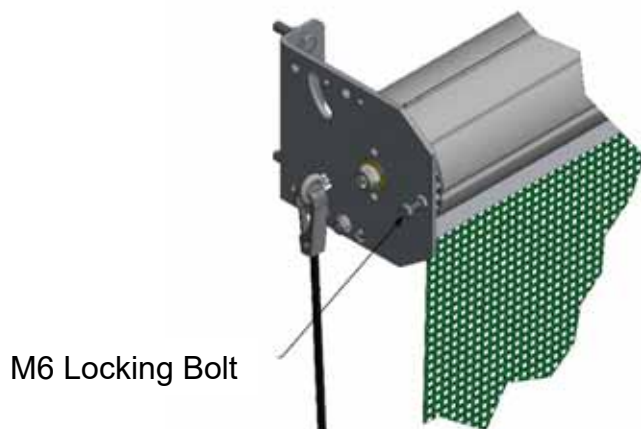

Fig 11a, Locking Bolt

Centralise the screen and secure each corner using 19mm self-drilling screws supplied (N1), the top fixings should be at the rear of the screen. It is important



to tension sheet sideways before fixing to remove creases (Figure 11b).

Shorten the rope pull (G1) to suit. Fit other cleat (K1) to bottom tube with 38mm self-drilling screws supplied (O1) and tie up rope to keep it clear of the ground.

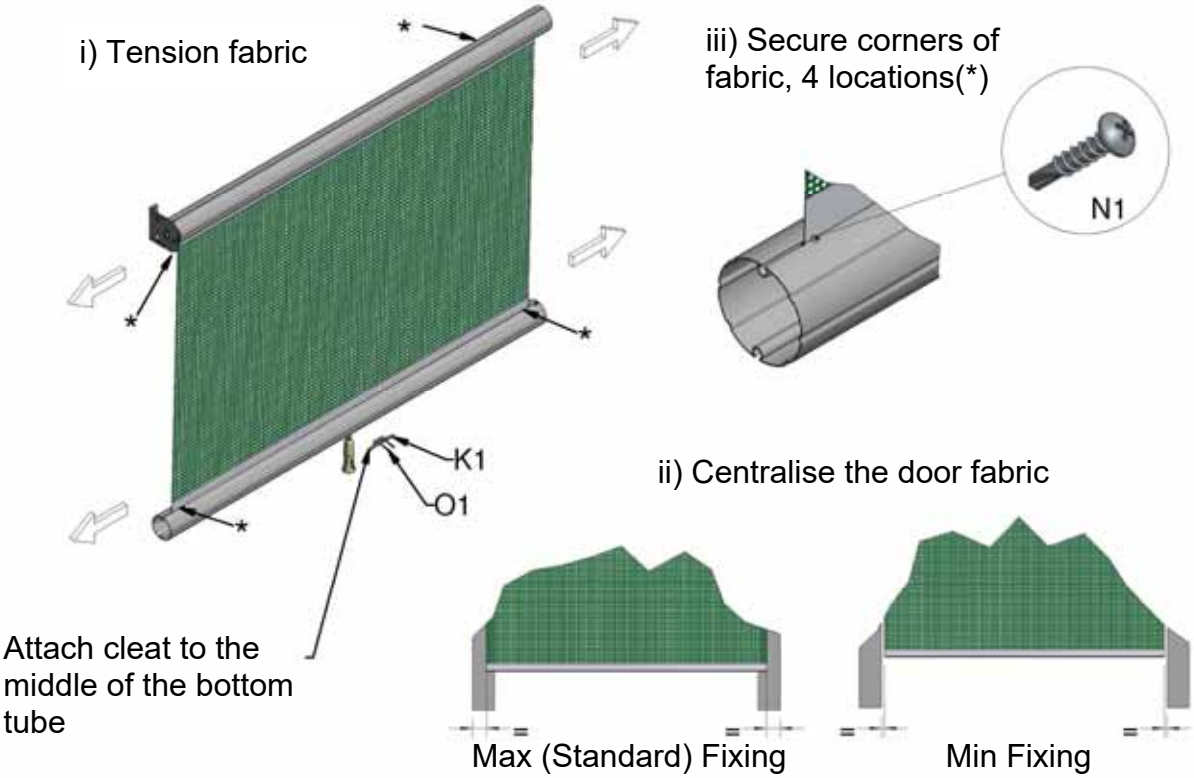

GB

Figure 11b, Centralising Screen

Attach the company detail label to the front of the bottom tube.

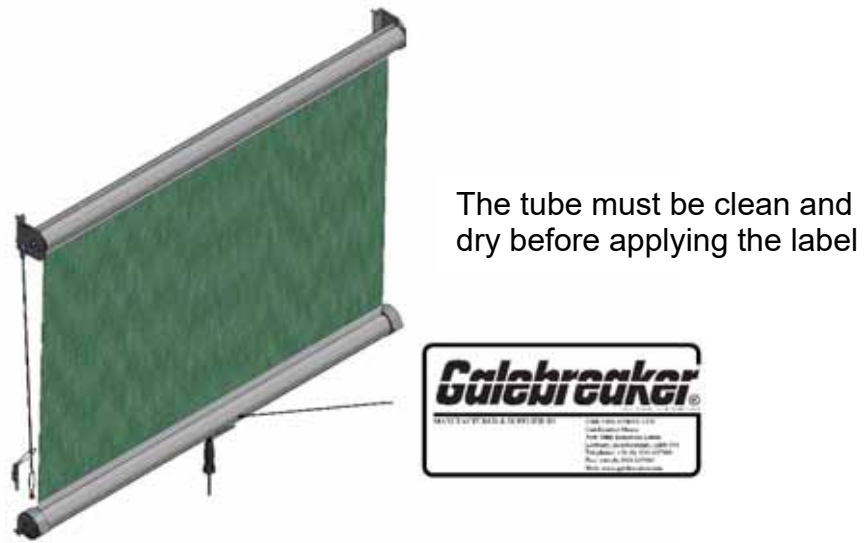

GB

Fig 12, Labels

11. Flap for Bottom Tube (Optional at extra cost)

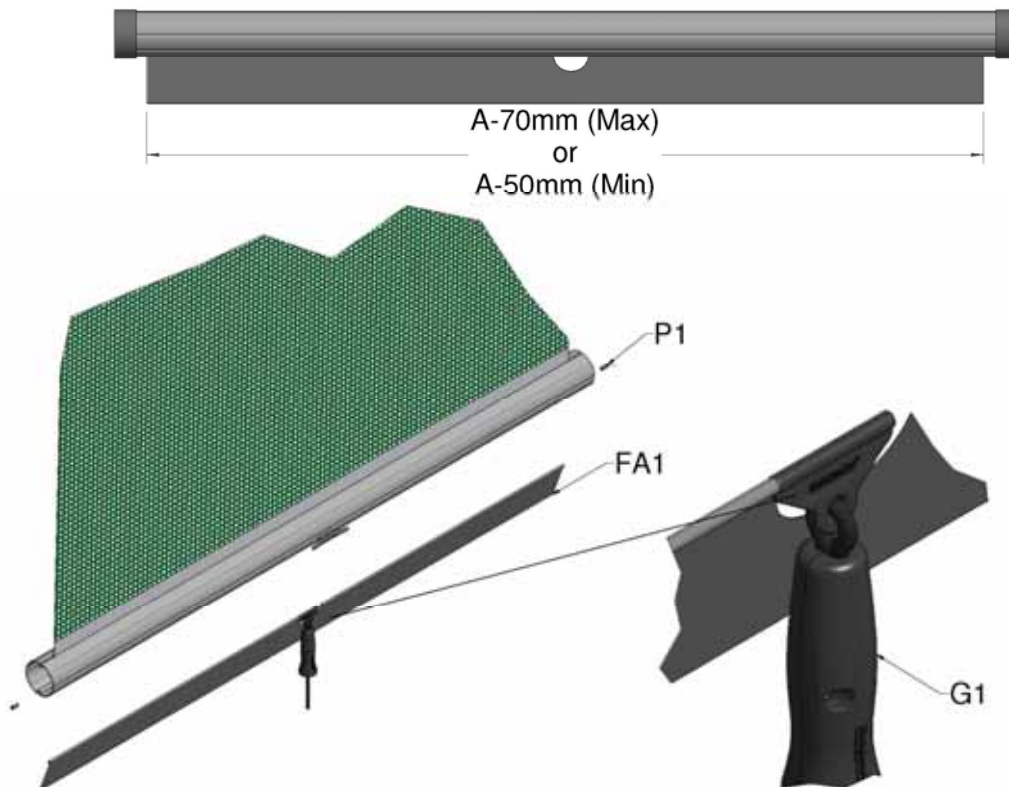

Figure 13, Bottom Flap Option

---

REF:	QTY	PART DESCRIPTION
FA1	1	Flap
FB1	1	6mm Nylon Insert (not shown)
P1	2*	Insert Lockers with Screws and Allen Key to Hold

\* These parts are included in standard fittings kit.

GB

Complete this operation in conjunction with Section 4:

- F1. Cut bottom flap (FA1) to same length as screen. Cut out semicircle in the pocket edge, with a diameter of 10cm to accept the rope pull (G1). Position is dependant on installation; we recommend it to be in the tube's centre. (Figure 13).
- F2. Cut and slide nylon insert (FB1) into the two pockets. Slide flap and rope pull into bottom flute. Secure each end with insert lockers (P1).

**NOTE: The rope pull is now in a fixed position, therefore the insert locker for the rope pull stop is not required.**

12. Door Cowling (Optional at extra cost)

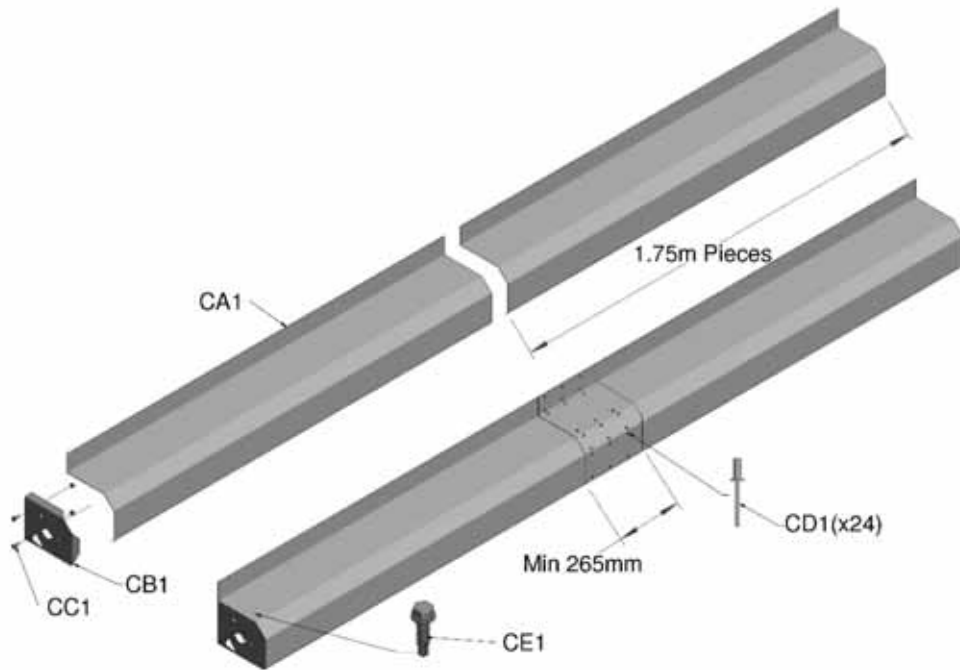

REF:	QTY	PART DESCRIPTION
CA1	*	1.75M Lengths of Cowling
CB1	2	End Cover
CC1	4	M8x20 Set Screw and Nyloc
CD1	24	M4.8 x 8 St Steel Rivets / per join
CE1	8	M5.5 x 19 Self Drilling Screws
CF1	1	5mm Drill for rivets (not shown)

Figure 14, Door Cowling Assembly

- C1. Fit the cowling ends (CB1) to the outsides of the drive & free end brackets using the M8x20 hex bolts and nuts.
- C2. Join the main cowling (CA1) with a minimum overlap of 265mm, using the M4.8 x 8 rivets, (CD1) 6 in each of the four faces. Fix the cowling to the mounting brackets, securing the end covers (CC1) under the main cowling using the M5.5 x 19 self-drilling screws (CE1), three per side.

**NOTE: The Cowling is self-supporting and does not require intermediate brackets.**

13. UKCA Marking Products under Construction Products Regulation

**It is the responsibility of the installer to check that the installation conforms to the specific safety features detailed in the Manufacturer’s Installation Instructions, to issue the Declaration of Conformity and mark a product under the Construction Products Regulation 305/2011.** To do this you will require the following which should be delivered with the product:

GB

- 1) This set of Installation Instructions (*operating and maintenance instructions*)
- 2) Maintenance Log Book, (*including Installation Checklist and Customer Declaration of Conformity*)
- 3) 1 x Declaration of Conformity (Installer Copy) – *to be completed*
- 4) A UKCA Label

**When CE marking a Galebreaker product, it is vital to follow the steps outlined below:**

- a) Install the product as per instructions, with no adaptations or modifications and complete of the *Health and Safety Checklist* in the Maintenance Log Book.
- b) Complete the two ‘Declarations of Conformity’ using the following:
  - **Model Type:** As shown on UKCA Label
  - **Serial Number:** As shown on UKCA Label
  - **Installation Company:** Your company name
  - **Date Installed:** Date Installed
  - **Declaration made by:** Responsible Person
  - **Declaration and Instructions received by:** Customer’s Signature
- c) Fix the supplied UKCA label to the bottom tube. The label should be accessible / visible. Where the serial number does not incorporate the door size, add the Product width and Product height to the end of serial number using a permanent marker pen. i.e. the full serial number should read

Serial Number:     1234 /     RS            W     X     H

[W] Product Width (m)

[H] Product Height (m)

- d) Your customer must be given a copy of the completed 'Maintenance Log Book' along with the 'Installation Instructions' supplied by Galebreaker. These should be stored adjacent to the door controls for reference purposes.
- e) Finally, ask your customer to sign the 'Declaration of Conformity' (Installer Copy). This important document must be filed back at the office of the installer for future reference

GB



Figure 15, UKCA Label Location

**YOUR SCREEN IS NOW READY TO USE.**

## **OPERATION AND MAINTENANCE OF THE SCREEN**

### ***How to use your Screen***

With the blind down, first release the spring locking mechanism by pulling on the rope (I1) and tie-off with the elasticated loop (J1) onto the wall mounted cleat (K1). Release bottom tube from 'J' brackets by pulling on tube mounted rope (G1) and allow the blind to recoil.

GB



**CAUTION: The recoil spring is quite powerful; ensure people are clear of the lower tube during operation.  
Take care when operating the product on windy days.**

**NOTE: The locking mechanism prevents surplus material unrolling off the top tube, when the lower tube is secured in the J brackets; IT IS NOT DESIGNED TO LOCK THE SCREEN AT VARIOUS HEIGHTS.**

With the screen fully up the rope pull can be slid to the side of the screen to for clearance.



### ***Adjusting spring tension***

#### **Decrease**

- a) Loosen the lock nut and engage M6 locking bolt on spring bracket onto the cog to prevent movement (Figure 16)



**CAUTION: To prevent injury ensure cog is securely fixed before proceeding.**



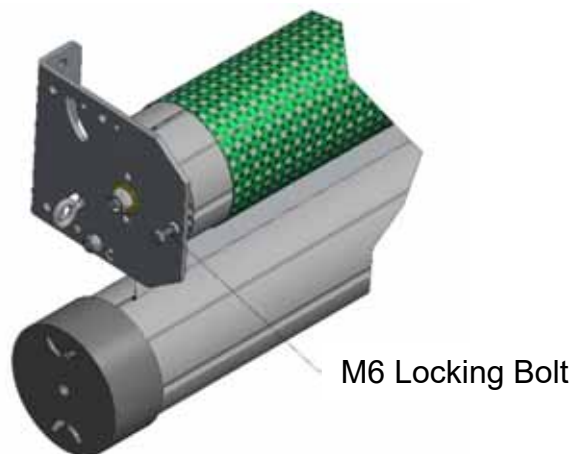

GB

Figure 16, Decreasing Sheet Tension

- b) Remove the bolts securing the spring bracket and unwind screen material from the top tube, we recommend adjusting the spring in increments of one revolution.
- c) Refit to building, release M6 locking bolt and allow surplus material to roll onto top tube. Unwind the locking bolt to clear the cog and secure with the lock nut again.

#### Increase

- a) Using the spanner supplied increase the spring tension (see section 8) a few 'clicks' at a time up to the maximum shown in Table 1.
- b) Make sure the lock nut on the outside of the mounting bracket is tight.

 <p><b>CAUTION: Make sure the M10 lock nut is tight.</b></p>
---

#### ***Maintenance of your Screen***

- Check annually for corrosion of the supporting bolts fixing the product to the building, the bolt holding the shaft into the top brackets and the blind in general. Replace suspect items to ensure it is safe for operators and bystanders alike
- The spring has a design life of 10,000 operations, which equates to using the door approximately 3 times a day for 10 years. After 10 years we recommend a

replacement spring be fitted, or following the dismantling instructions given below remove the spring annually to ensure it has not broken.

- Lubricate the spring locking mechanism
- Lubricate the rope pull slide
- Should Screen material be damaged, repair with special repair kit (code SPS-99) available from your Galebreaker dealer, importer or head office.
- Keep the instructions supplied for reference purposes.

GB

### ***How to dismantle your Screen***

Follow the installation instructions in reverse order. In particular follow this sequence before unbolting the top brackets to remove the roller assembly and recoil spring.

1. Raise blind fully.
2. Engage M6 locking bolt on spring bracket onto the cog to prevent movement (Figure 16)
3. Unbolt top brackets and remove complete assembly.



**CAUTION: To prevent injury ensure cog is securely fixed before proceeding.**

**NOTE:** Tried and tested in the harshest weather conditions, a summary of our guarantee is as follows, see our website for full details:

- **Mechanical components: 100% guarantee for two years, followed by an eight year graduated guarantee.**

GB

**RAIN INGRESS:** Please note that in extreme weather conditions some moisture will penetrate a mesh material.

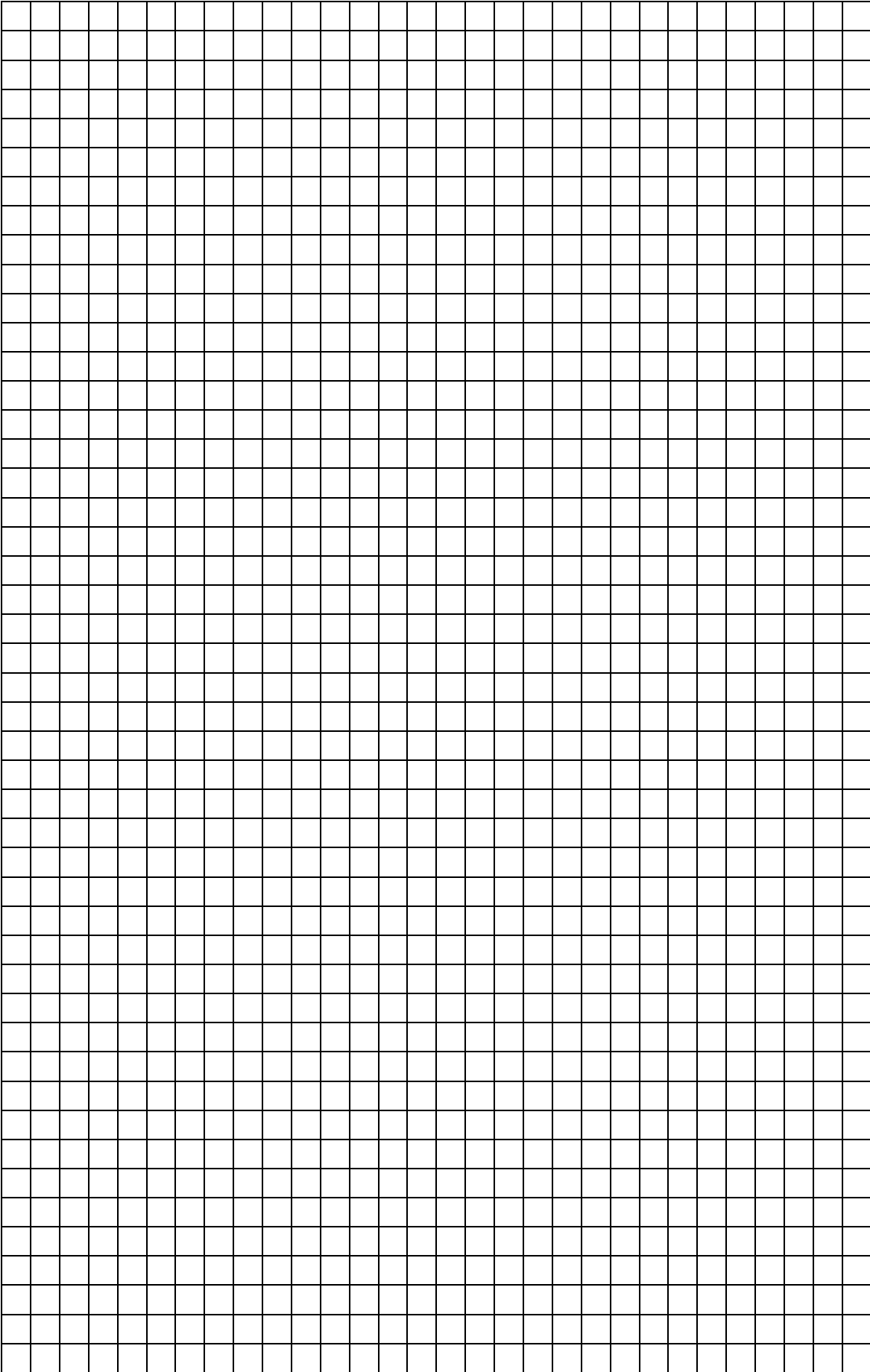

GB

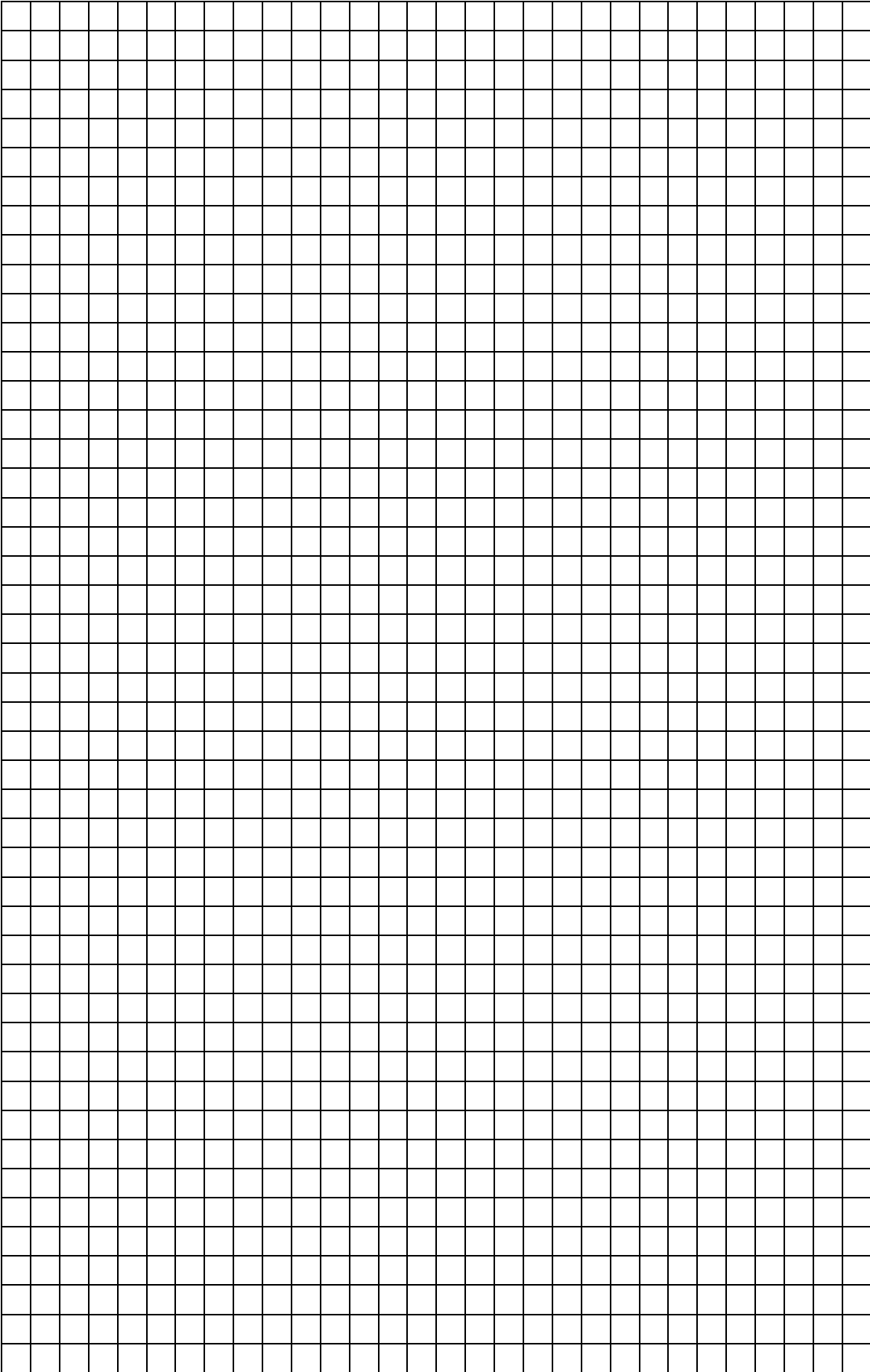

GB



**Manufacturer:** Galebreaker Agri Ltd                      **Tel:** +44 (0) 1531 637 900  
Galebreaker House    **Fax:** +44 (0) 1531 637 901  
New Mills Industrial Estate  
Ledbury  
Herefordshire, UK  
HR8 2SS

**[www.galebreaker.com](http://www.galebreaker.com)**

Designed and Manufactured in the UK by Galebreaker Agri Ltd.,  
Original Instructions

© Copyright Galebreaker Agri Ltd 2021. All Rights reserved

**Model No: RS/Mk7/15/12**

**Instruction Ver: 2021/12/GB**