

# CATTLE CRUSH USER'S GUIDE

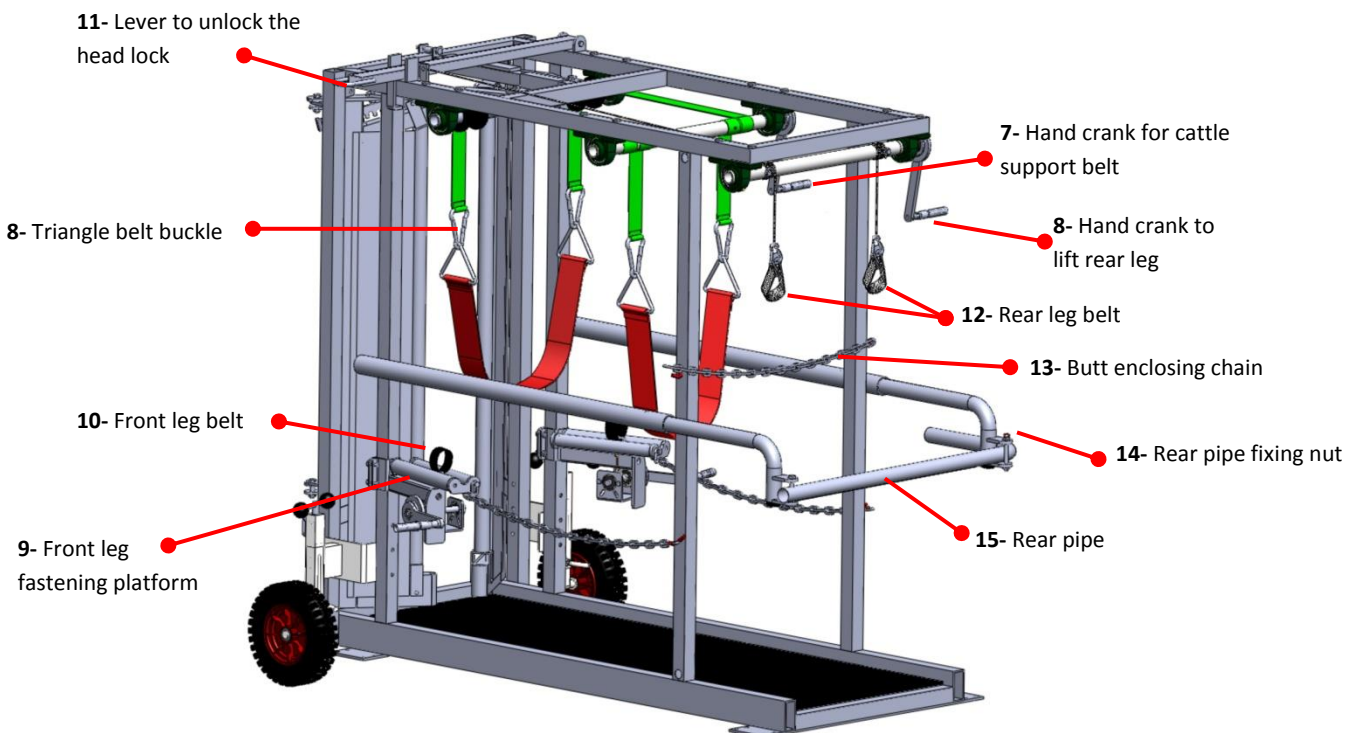
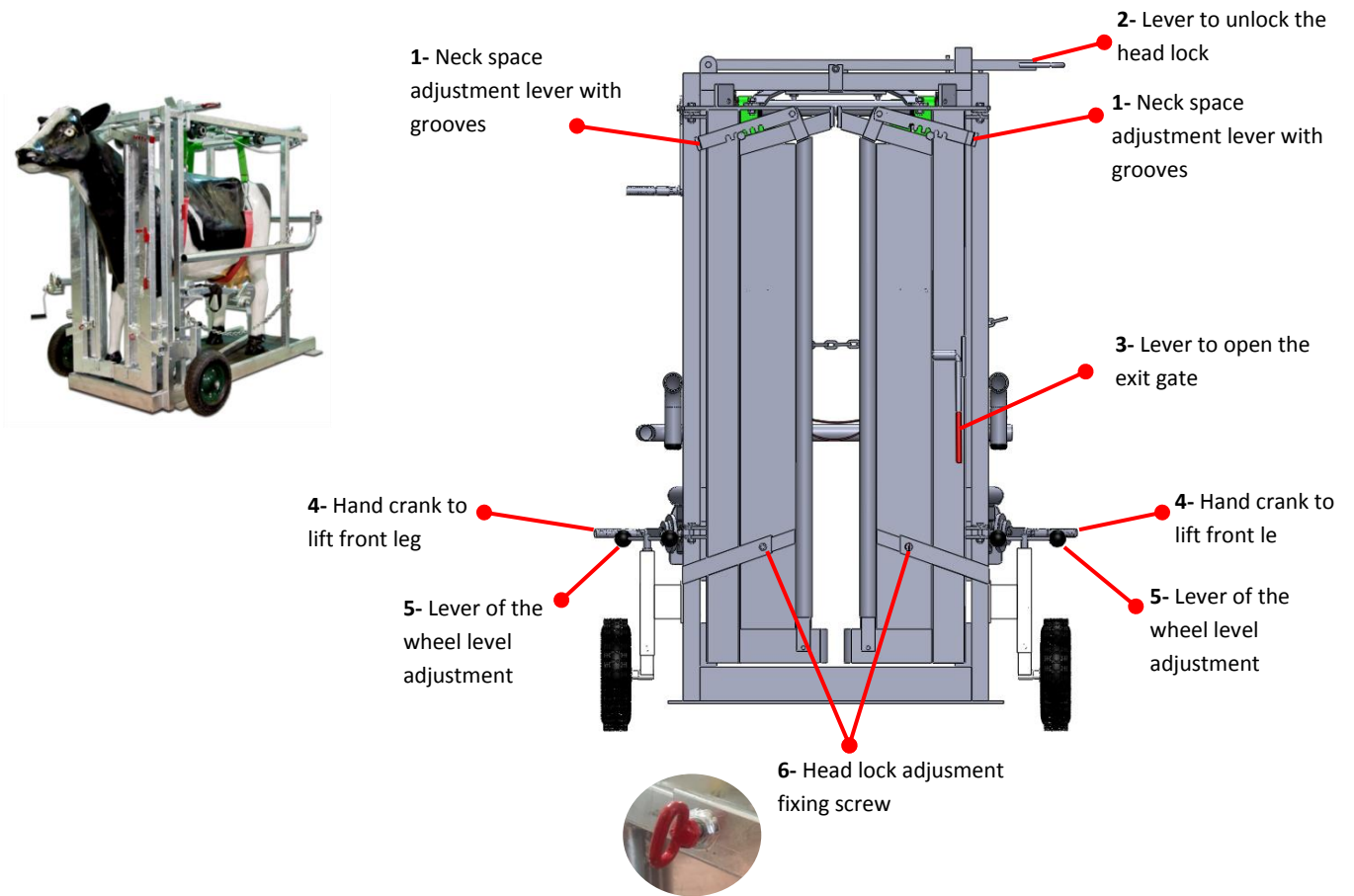

Before using, wheels should cut from the ground for stability by loosen the lever of the wheel level adjustment.

## Adjustments of the Cattle Crush

Make adjustments below before using.

**1. Neck space adjustment:** Neck space adjustment is made according to the neck and head sizes of the cattle to be hoof trimming.

The front (exit) gate can be set to 5 different the locking position by the grooves. The setting must be symmetrical for both lever with grooves.

After neck space adjustment, fix the adjustment with fixing nuts.

Front view of the crush

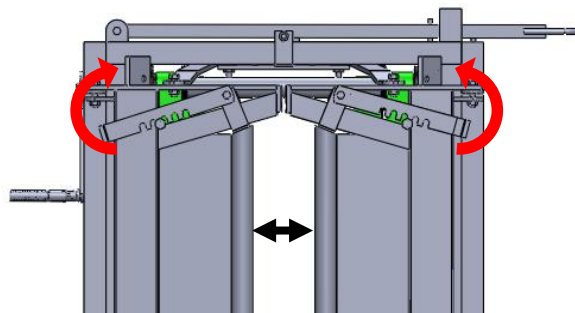

**2. Length adjustment:** You can set to 3 different length position with fixing bolts.

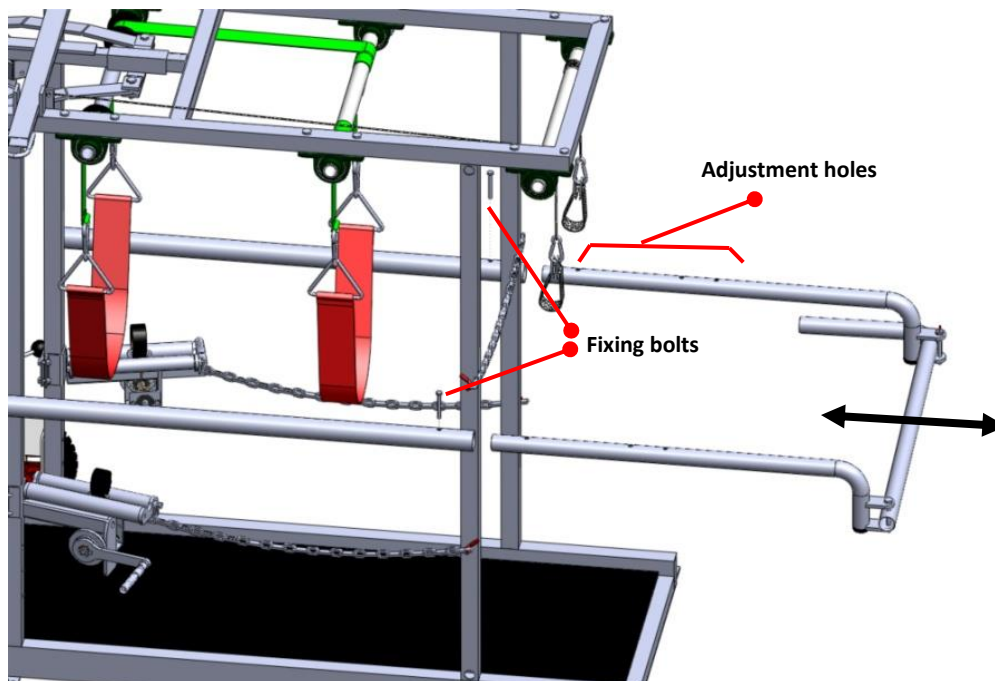

## Before the cattle moved into the crush;

- Rear pipe should be open so remove the screw and then open the rear pipe as shown beside.
- Remove the one side of the butt enclosing chain.
- One side of belly straps (Belts) should be unlocked.

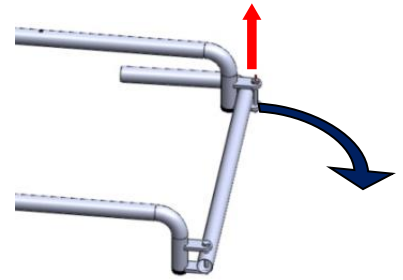

## During cattle moved into the crush; (Images are top views)

### Entering Position of the Exit Gate

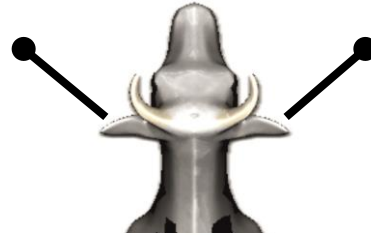
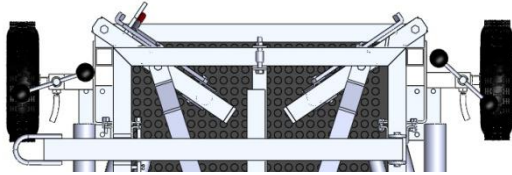

It is the position where the animal will go into the Crush.

### Head locking position of the Exit Gate

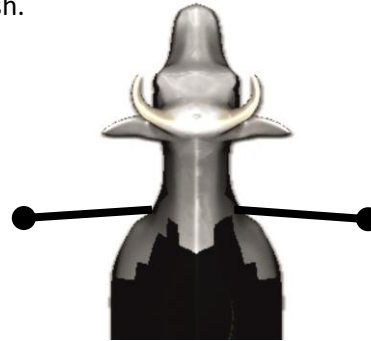
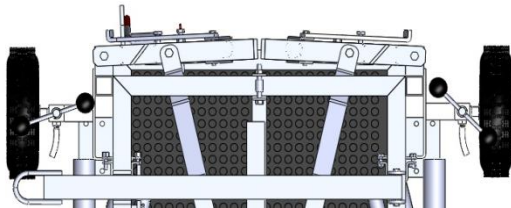

It is the position in which the animal locks its neck by pushing the gate with its body.

## After cattle moved into the crush;

- Attach the butt enclosing chain.
- Close the rear pipe and then fix the pipe with its screw.
- Belly belts passed under of the cattle and belly straps are attached.
- Bring the belly belt up under the belly of the cattle.
- Turn the hand crank of belly belts to support the cattle.
- **Purpose of belly belts are not lifter, it only supports the cattle.**
- Place the belt around the rear leg and lift the leg.
- Process rear legs one by one.
- **You must lift legs one by one. It means always 3 legs must be on the ground.**
- Allow the leg to drop and release it.
- Attach the front leg with the belt. Turn the hand crank of the front leg belt until the leg is fixed to the front leg support.
- Process the front hoof.

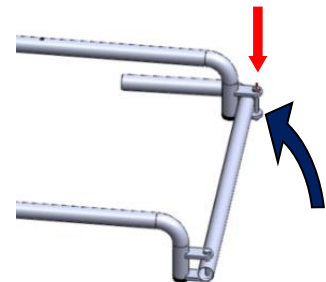

- Release the short tension rope.
- Unhook the rope.
- Reverse the hand crank the belly belt is on the ground.
- Check that all ropes and belts have been freed.
- Lift the lever of the head lock to unlock the front (exit) gate.
- Pull the lever of the front (exit) gate
- Lead the cow out of the crush.

### Exit Position

Lever to open the exit gate (part number: 3)

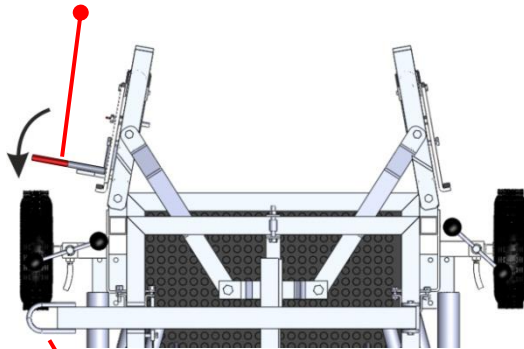

Lever to unlock the head lock (part number: 2)

